

CONTEMPORARY

V G

I Z

L L

ALIVAR

Nuovi oggetti d'arredo per dare carattere alla vita, complementi per farsi circondare da idee luminose, soluzioni per ambienti ad alto livello funzionale ed estetico. ALIVAR continua il progetto di una casa dove ogni dettaglio ha un valore squisito, dove ogni elemento è un punto d'interesse e concentra intorno a sé il piacere e il dinamismo. Una casa ricca d'ispirazioni, multicentrica, dove l'essenzialità lascia gli spazi aperti e dà ottima vivibilità, dove essere di tendenza significa anticipare ciò che c'è oltre l'orizzonte.

New furnishing items to give a true touch of character, furnishings to highlight the surroundings with lighting features, ideal solutions for highly functional and modern environments. ALIVAR range continues an ongoing project in which each detail has a specific intrinsic value and in which each element has a true significance focused on comfort and dynamism. For a home that is a true source of inspiration, multi-centered, in which minimalist lines provide the scope for excellent visibility, and fashion trends are conceived as an anticipation of what lies beyond the horizon.



SISTEMI E COMPLEMENTI\_WALL UNITS

Off-Shore	pag: 7
Frame Collection	pag: 19

PORTA\_TV\_TV UNITS

Folio	pag: 37
HF2_HF3	pag: 39

LIBRERIE\_BOOKCASES

Wavy	pag: 41
Shelf-Service	pag: 47
Ibis	pag: 51
Surface	pag: 57

DIVANI E POLTRONE\_SOFAS AND ARMCHAIRS

Ascot	pag: 63
Daytona	pag: 69
Dover	pag: 75
Haero	pag: 81
Madison	pag: 87
Soho	pag: 91
Sbend	pag: 95
Boss	pag: 97

POLTRONCINE\_LOUNGE CHAIRS

Buddy Boss	pag: 101
Club	pag: 105
Atlanta	pag: 109
Wing lounge chair	pag: 115
Samoa	pag: 121
Simple Armchair	pag: 127
Internos	pag: 129
Fortuna	pag: 133
Lolly	pag: 137

PANCHE\_BENCHES

Tech	pag: 141
Boss Bench	pag: 145
Onda	pag: 147
Snake	pag: 149
Cartesiano	pag: 151

MADIE E CONTENITORI\_SIDEBOARDS AND CABINETS

Altea	pag: 153
Edomadia	pag: 161
Kubit	pag: 167
Portland	pag: 173
Denver	pag: 181
Cubic	pag: 187
Slide	pag: 191
Container	pag: 197

TAVOLI\_TABLES

Radar	pag: 205
Loto	pag: 209
XT	pag: 215
Big Table	pag: 219
Vernissage	pag: 223
Cut	pag: 229
Biplano	pag: 241

SEDIE E SGABELLI\_CHAIRS AND STOOLS

Axia	pag: 245
Wing chair	pag: 249
Tango	pag: 251
Jazz	pag: 253
Lollipop	pag: 255
Simple chair	pag: 261
Ice P	pag: 263
Ice S	pag: 265
Kiron	pag: 267

TAVOLINI\_SIDE TABLES

Harpa	pag: 271
UP	pag: 277
Daytona	pag: 279
Club	pag: 281
Bench	pag: 283

LETTI\_BEDS

Blade/B	pag: 285
Blade/A	pag: 291
Echo	pag: 293
Feng	pag: 299
Kendo	pag: 303
Plaza	pag: 307
Bed Boss	pag: 311

COMPLEMENTI NOTTE\_BEDROOM COMPLEMENTS

Esprit	pag: 317
Edo	pag: 321
Fjord	pag: 327
Frame	pag: 335

COMPLEMENTI\_ACCESSORIES

Frame	pag: 337
Look at me	pag: 339
Quadrus	pag: 343
Ab Normal	pag: 345

SCHEDE TECNICHE\_TECHNICAL SHEETS pag: 348

SISTEMI E  
COMPLEMENTI  
WALL UNITS





OFF-SHORE sistema modulare composto da pannellature, basi in MDF laccato lucido o opaco. Illuminazione a led. Ripiani, cassettiere e vetrine in laccato lucido, opaco o noce canaletto. Anta scorrevole in cristallo temperato trasparente o fumè con telaio in alluminio anodizzato. naturale o bianco\_

OFF-SHORE. Modular system made of wall panels and baseboards in glossy or matt lacquered MDF. Led lighting. Shelves, cabinets and drawers units made of glossy or matt lacquered MDF or Canaletto walnut. Sliding doors in tempered glass, clear or smoke-grey with frame in anodised aluminium, natural or white\_



# SISTEMI E COMPLEMENTI WALL UNITS

La retro illuminazione LED delle mensole in MDF, nelle finiture laccato lucido o opaco, nei colori bianco, tortora o noce Canaletto, oltre ad un utilizzo pratico, valorizza la composizione e la rende parte creativa dell'arredamento\_

The LED backlighting featured in the MDF shelving, which comes in white, dove-grey or Canaletto walnut with either a glossy or matt lacquer finish, is not only a practical addition but also adds value to the composition, making it a creative part of the furnishings.\_











OFF-SHORE\_ Sistema modulare\_Modular system\_

Supporto per TV al Plasma/LCD. Garantisce una posizione ottimale di visione con funzioni di inclinazione, rotazione e ripiegamento. Plasma/LCD bracket that attaches to panel. Ensures perfect viewing experience thanks to tilt, swivel and reach functions.







Il porta tv e hi-fi è progettato per dare una sistemazione ordinata ed elegante ai dispositivi tecnologici di cui abitualmente ci circondiamo nel living\_

The TV and hi-fi unit is designed to provide organized, elegant storage for the technological devices that generally surround us in our living space\_







FRAME COLLECTION\_ Sistema modulare\_Modular system\_

Il pensile a quattro ante laccato lucido rosso scuro valorizza geometrie orizzontali e verticali, componendo un delicato puzzle che fa da scrigno agli oggetti della nostra quotidianità\_

The dark red glossy lacquered wall unit with four doors displays horizontal and vertical shapes and forms a delicate puzzle that serves as a precious case for everyday objects\_





# SISTEMI E COMPLEMENTI WALL UNITS

FRAME COLLECTION\_ Sistema modulare\_Modular system\_

Laccato lucido nero, con mensole in alluminio spazzolato, si coglie  
il fascino di un progetto si pensato ma poi scelto con il cuore\_

Black glossy lacquered with anodized aluminium shelves transmits  
the charm of a design that is well-planned yet lovingly chosen\_











# PORTA TV TV UNITS

Elemento porta TV/Hi-Fi con foro passacavi. Pannello in legno laccato lucido. Laccato opaco o in rovere. Colonnine laterali porta CD/DVD in alluminio. Mobiletto in alluminio verniciato per videoregistratore/decoder.

Television/Hi-Fi unit with an oak veneer or in glossy or matt lacquered wood. Arranged with cables raceway. Aluminium CD/DVD rack on both sides. Shelves in painted aluminium for DVD/Video recorder. Fluorescent light.





FOLIO\_ Porta TV\_TV Unit\_

Elemento porta TV/Hi-Fi disponibile in rovere, laccato lucido o opaco con fori passacavi. Basamento in acciaio laccato alluminio. Colonnine laterali porta DVD in alluminio\_

Television/Hi-Fi unit in wood with an oak veneer or in glossy or matt lacquered wood. Arranged with cables raceway. Basement in aluminium-painted steel. Aluminium DVD rack on both sides\_



HF2\_ Porta TV\_TV Unit\_design\_Giuseppe Bavuso\_

# LIBRERIE BOOKCASES

WAVY è un sistema di librerie che coniuga in modo rigoroso design e funzionalità. Un prodotto minimale in cui la sottile struttura dal disegno ondeggiante, sia in verticale che in orizzontale, conferisce all'insieme un'immagine di grande solidità e leggerezza. Estremamente caratterizzata nell'accuratezza dei dettagli e nell'utilizzo dei materiali, Wavy è realizzata completamente in "Hi-Macs Natural Acrylic Stone" della LG nel colore bianco S28 Alpine White.

WAVY is a bookcase system that combines the utmost of design and functionality. A minimalist product with a thin, wavy structure, both vertically and horizontally, gives an overall impression of being solid yet lightweight. With its extremely characteristic accuracy of details and the use of materials, Wavy is made entirely in "Hi-Macs Natural Acrylic Stone" by LG in S28 Alpine White.



DAYTONA, divano in pelle bianca, con gambe in acciaio  
HARPA tavolini in due altezze, SAMOA poltroncine rivestite in pelle  
con struttura in acciaio. WAVY libreria asimmetrica modulare in LG  
HI-MACS Natural Acrylic Stone \_

DAYTONA, sofa in white leather with steel legs  
HARPA coffee tables available in two heights, SAMOA armchairs  
upholstered in leather with steel frame. WAVY, an asymmetric  
modular bookcase in LG HI-MACS Natural Acrylic Stone \_





WAVY è componibile a piacere:  
in verticale per sovrapposizione con modulo H. 36,  
in orizzontale è costituita da 3 elementi accostabili:  
63 / 124 / 185 cm\_

WAVY may be arranged as desired:  
superimposed vertically with module H. 36,  
or horizontally, composed by 3 elements which  
may be combined: 63 / 124 / 185 cm\_







SHELF-SERVICE libreria in finitura laccato bianco. Tavolo CUT e sedie JAZZ\_

SHELF-SERVICE bookcase in white lacquer. CUT table and JAZZ chair\_

Libreria componibile. Struttura in acciaio verniciato o cromato.  
Ripiani in legno disponibili nelle seguenti finiture: laccato lucido,  
laminato liquido, laccato opaco, rovere\_

Sectional bookcase. Frame in chrome-plated or painted steel.  
Wooden shelves available in the following finishes: glossy  
lacquered, liquid laminate, matt lacquered, oak\_





IBIS. Libreria con ripiani in vetro colorato nero, pouff ONDA\_

IBIS. Shelving with black coloured glass top. ONDA ottoman\_



Libreria con staffa di supporto per fissaggio al muro in acciaio laccato. Cavi autofillettanti in acciaio inox di varie misure. Accessori: ripiani e contenitori in rovere laccato opaco o laccato lucido. I ripiani possono essere anche in cristallo temperato, trasparente o colorato.

Bookcase with support bracket for wall fixing in painted steel. Self-threading stainless steel cables in different sizes. Shelves and cabinets in oak, glossy lacquered or matt lacquered. Shelves are also available in tempered clear glass or colored glass.



IBIS. Libreria con ripiani in finitura rovere tinto wengé.  
divano in pelle art. 633 (Alivar Museum)\_

IBIS. Shelving with wengé-stained oak tops. Sofa covered  
in leather art. 633 (Alivar Museum)\_

# LIBRERIE BOOKCASES

Libreria in MDF laccato lucido o opaco.  
In questa pagina la versione bifacciale laccata opaca con inserto verticale in "pietra Leccese" \_

Bookcase in glossy or matt lacquered MDF.  
On this page, the double-sided version in matt lacquer with vertical insert in "Leccese stone" \_







SURFACE\_Libreria\_Bookcase\_



Libreria disponibile in MDF laccato lucido o opaco. Qui nella versione laccata lucida bicolore\_

Bookcase available in glossy or matt lacquered MDF. Shown here in the double-colour glossy lacquer version\_





# DIVANI E POLTRONE SOFAS AND ARMCHAIRS

Struttura in legno ricoperta in poliuretano indeformabile e fodera in tomana. Cuscini spalliera in piuma d'oca. Cuscini seduta in poliuretano indeformabile e fodera in tomana. Base in alluminio anodizzato lucido.

Rivestimento in tessuto o pelle\_

Wooden frame covered in non-deformable polyurethane foam with synthetic lining. Back cushions in down. Seat cushions made of non-deformable polyurethane foam with synthetic lining. Base in polished anodized aluminium. Fabric or leather covers\_



ASCOT due divani in pelle bianca e base in alluminio lucido. Tavolini quadrati DAYTONA con piano laccato lucido bianco e base in acciaio cromato. Sullo sfondo il tavolo RADAR e le sedie WING CHAIR\_

ASCOT sofas in white leather with polished aluminium base. DAYTONA coffee tables with glossy white top and chrome-plated steel base. In the background RADAR table and WING CHAIR\_



ASCOT divano in tessuto con base in alluminio lucido. Tavolini DAYTONA con piano laccato lucido bianco e base in acciaio cromato. Credenza EDMOMADIA laccata lucida bianca\_

ASCOT sofa in fabric with base in polished aluminium. DAYTONA coffee tables with a glossy white lacquered top and chrome-plated steel base. EDMOMADIA sideboard with a glossy white finish\_



Semplicemente DAYTONA il divano contemporaneo vestito di pelle bianca. HARPA tavolini con struttura in acciaio cromato e piani in ebano e in marmo cristallizzato. WAVY libreria componibile in pietra acrilica bianca LG Hi-Macs\_

Simply DAYTONA – the contemporary sofa upholstered in white leather. HARPA coffee tables with chrome-plated steel frame and tables in ebony and crystalized marble. WAVY modular bookcase in LG Hi-Macs white Natural Acrylic Stone\_



Una raffinata interpretazione: DAYTONA divano e  
chaise-longue in pelle bianca, poltroncine ATLANTA  
con braccioli e tavolini DAYTONA\_

A refined interpretation: DAYTONA sofa and chaise  
longue in white leather, ATLANTA lounge chair with  
armrests and DAYTONA coffee tables\_

Divano con struttura in legno con cuscini imbottiti in poliuretano e piuma d'oca. Base e gambe in acciaio verniciato o cromato. Disponibile con bracciolo basso (B) e alto\_

Sofa with wooden frame. Cushions in polyurethane foam and goose down. Steel base and legs, painted or chrome-plated. Available with low (B) or high armrest\_

DAYTONA\_Divano\_Sofa\_

Un living estremamente raffinato.

ALTEA medie laccate lucide,

DOVER divani in pelle con gambe in acciaio,

HARPA tavolini in tre altezze,

SAMOA poltroncine in pelle intrecciata con struttura in acciaio, WAVY libreria asimmetrica modulare in

LG Hi-Macs Natural Acrylic Stone\_

Extreme refined living,

ALTEA glossy lacquered sideboards,

DOVER sofas in leather with steel legs,

HARPA coffee tables available in three heights,

SAMOA armchairs upholstered in woven leather with a steel frame, WAVY, an asymmetric modular

bookcase in LG Hi-Macs Natural Acrylic Stone\_

ALTEA madie laccate lucide,  
DOVER divano in pelle con gambe in acciaio,  
HARPA tavolini in tre altezze,  
SAMOA poltroncine in pelle intrecciata con  
struttura in acciaio\_

ALTEA glossy lacquered sideboards,  
DOVER sofa in leather with steel legs,  
HARPA coffee tables available in three heights,  
SAMOA armchairs upholstered in woven leather  
with a steel frame\_



Divano DOVER. Struttura in legno rivestita in poliuretano indeformabile e fodera in tomama. Cuscino seduta in gomma poliuretana e Dacron. Cuscino spalliera in piuma d'oca. Gambe in acciaio cromato o laccato\_

DOVER sofa. Wooden frame covered with non-deforming polyurethane foam with tomama lining. Seat cushion in polyurethane foam and Dacron. Back cushion in down. Chrome-plated or painted steel legs\_

HAERO divani in pelle nera serviti dal tavolino  
centrale BENCH a due cassettei bianco lucido.

HAERO sofas in black leather with BENCH coffee  
table in white glossy lacquer with two drawers.



Struttura in legno ricoperta in gomma poliuretanic  
e dacron. Base in trafilato di alluminio spazzolato.  
Rivestimento in tessuto o pelle.

Wooden frame covered in polyurethane foam and  
dacron. Base in brushed aluminium. Fabric or  
leather covers.





HAERO\_Divano\_Sofa



MADISON divano in pelle bianca e pouff in pelle nera\_

MADISON sofa in white leather with ottoman in black leather\_



MADISON\_Divano\_Sofa\_

Atmosfera suggestiva con il divano componibile MADISON in abbinamento con il pouff e il tavolino UP laccato lucido nero.

A subtle atmosphere with the MADISON sofa combined with the ottoman and UP coffee table in black glossy lacquer.



SOHO divani con base in rovere. Spalliera reclinabile in acciaio e rivestimento in pelle o tessuto. Tavolino BENCH in rovere tinto wengé

SOHO sofas with oak base. Reclining back in steel with fabric or leather cover. BENCH table in wengé-stained oak



Flessibilità funzionale per il divano SOHO con spalliera reclinabile per favorire il relax della seduta. In questa foto nella versione in pelle\_

Flexible and functional, the SOHO sofa with the reclining back favours a relaxed seating. In this photo the leather version\_





SBEND divano rivestito in pelle bianca. Tavolino HARPA\_

SBEND sofa covered in white leather. HARPA coffee-table\_





BOSS. divano in pelle bianca con struttura in acciaio verniciato.  
Libreria bifacciale SURFACE\_

BOSS. sofa in white leather. base in steel tube painted.  
SURFACE double-faced bookcase\_



Boss divano in pelle nera. Tavolino con piano in cristallo art. 269 (Alivar Museum) libreria IBIS con ripiani in vetro colorato nero\_

Boss sofa in black leather. Low table with glass top art. 269 (Alivar Museum). IBIS shelving with black coloured glass shelves\_



# POLTRONCINE LOUNGE CHAIRS

BUDDY BOSS\_Poltroncina\_Armchair\_design\_Bruno Rainaldi\_

Struttura in acciaio rivestita in poliuretano. Base in tubo di acciaio cromato o laccato. Rivestimento in pelle o tessuto\_

Steel frame covered with polyurethane foam. Base in chrome-plated or painted steel. Covered in fabric or leather\_



101

POLTRONCINE\_LOUNGE CHAIRS\_



BUDDY BOSS\_Divanetto\_Small sofa\_



CLUB poltroncina in pelle o fintapelle con la base in acciaio cromato. Uno spazio relax completato dai tavolini CLUB.

CLUB lounge chair in leather or synthetic leather with base in chrome-plated steel. A relaxing space completed with the CLUB coffee tables.



CLUB\_Poltroncina\_Lounge chair\_

CLUB è il risultato di un design sofisticato, giocato sull'accostamento dei volumi: viene proposta in tonalità naturali, che esaltano la particolarità delle linee e aggiungono classe all'insieme.

CLUB lounge chair is the result of sophisticated design: proposed in natural colours that emphasises the lines and add a touch of class.



ATLANTA poltroncina con o senza braccioli in  
acciaio si abbina ai tavolini UP\_

ATLANTA lounge chair with or without armrests  
combined with UP coffee tables\_



109





ATLANTA\_Poltroncina\_Lounge chair\_

Estremamente elegante la lavorazione del rivestimento  
trapuntato in pelle delle poltroncine ATLANTA\_

The ATLANTA lounge chair is extremely elegant in its leather  
padded upholstery\_



ATLANTA per comporre all'infinito,  
ideale per il living, l'attesa e  
la reception\_

ATLANTA products are ideal and  
suitable for both domestic and  
contract settings\_

# POLTRONCINE LOUNGE CHAIRS

In WING LOUNGE CHAIR design e gusto nordico si intersecano come si intrecciano le fibre di corda sulla spalliera e sulla seduta, dando origine ad un sofisticato motivo\_

The WING LOUNGE CHAIR has a northern design flavour, the cord is woven along the back and seat, creating a sophisticated theme\_



115

POLTRONCINE\_LOUNGE CHAIRS\_

WING LOUNGE CHAIR con seduta e spalliera in corda intrecciata colore naturale o nera oppure rivestita in pelle.

Struttura in acciaio nelle finiture cromo, nickel nero o verniciata colore bianco, nero o alluminio\_

WING LOUNGE CHAIR with seat and back in woven cord, either black or natural, or with leather upholstery. The frame

is made of laser-cut steel with choice of finishes: chrome, black nickel or painted in black, white or aluminium\_





WING LOUNGE CHAIR\_Poltroncina\_Lounge chair\_

Poltroncina SAMOA nella versione in pelle intrecciata e struttura in acciaio laccato, per un effetto total white. La sua forma essenziale si abbina facilmente ai divani della collezione ALIVAR\_

SAMOA armchair upholstered in woven leather and a painted steel structure for an all-white effect. Its essential form can be easily combined with ALIVAR collection sofas\_



121

POLTRONCINE\_LOUNGE CHAIRS\_

Flessibile o rigorosa? La poltroncina Samoa si fa interpretare delle contraddizioni della vita quotidiana, accostando alle linee dolci di seduta e schienale quelle spigolose e nette della base. Un mix di stili che la rende idonea ad ogni ambiente e circostanza\_

Flexible or not? The Samoa armchair is perfect for dealing with all of life's little contradictions, combining the gentle lines of the seat and back with the sharp angular lines of its base. A mixture of styles that make this armchair ideal for any time or place\_



SAMOA\_Poltroncina\_Lounge chair\_



Placevole passe-partout, la poltroncina SAMOA si distingue per la linea sinuosa di seduta e schienale qui nella versione con trama intrecciata, in contrasto con il rigore della base squadrata. Seduta e schienale sono realizzati in poliuretano rivestito a scelta in pelle, ecopelle o cavallino, mentre la struttura è disponibile in tubolare di acciaio laccato o cromato\_

A versatile passe-partout, the SAMOA armchair stands out for the sinuous lines of the seat and back, here in version with woven seats to contrast the sharply squared base. Seat and back are made in polyurethane covered in leather, synthetic leather, or pony skin, while the frame is available in either painted or chrome-plated tubular steel\_





SIMPLE ARMCHAIR. Poltrona con struttura in tubo d'acciaio cromato o verniciato. Seduta e spalliera in gomma poliretanica e Dacron.

SIMPLE ARMCHAIR. Armchair with chrome-plated or painted steel frame. Seat and back made of polyurethane foam and Dacron.



127

Struttura in legno ricoperta in gomma poliuretanica e dacron.  
Rivestimento in tessuto o pelle. Piedi cromati\_

Wooden frame covered in polyurethane foam and dacron.  
Leather or fabric covers.Chrome-plated feet\_





Poltroncine nella versione in pelle. Tavolino art. 799 (Alivar Museum)\_

Armchairs covered in leather. Low table art. 799 (Alivar Museum)\_

Struttura in legno massello ricoperta in poliuretano e dacron. Rivestimento in pelle o tessuto.

Frame in solid wood covered with polyurethane foam and dacron. Leather or fabric cover.





Poltrone rivestite in cavallino\_

Armchairs covered in cow hide\_

Struttura in piatto di acciaio cromato o verniciato. Cuscino  
seduta in poliuretano e dacron rivestito in tessuto o pelle.  
Spalliera in cuoio\_

Frame made of painted or chrome-plated flat steel.  
Upholstered seat cushion, covered in leather or fabric. Back  
covered in hide\_





LOLLY\_Poltroncina\_Lounge chair\_



Poltroncine nella versione in pelle bianca\_

Armchairs covered in white leather\_



139

# PANCHE BENCHES

TECH panca con rivestimento in pelle nera e bianca.  
Paravento art. 400 (Alivar Museum)\_

TECH bench with white and black leather covers.  
Screen art. 400 (Alivar Museum)\_





TECH. panca rivestita in pelle bianca e struttura in acciaio cromato.

TECH. bench covered in white leather with chrome-plated steel frame.





BOSS pouff/panca, disponibile in tre misure diverse,  
120x120, 120x60 e 160x60 cm.  
Qui rivestiti in pelle bianca e nera \_



BOSS ottoman/bench, available in three different sizes,  
120x120, 120x60 e 160x60 cm.  
Shown in black and white leather \_





ONDA ,pouff in pelle bianca e cuscino in pelle nera.  
Paravento art. 400 (Alivar Museum)\_

ONDA ottoman covered in white leather and armrest  
in black leather. Screen art. 400 (Alivar Museum)\_

Panca curviforme accostabile all'infinito.  
Accostando gli elementi tra di loro si possono  
creare insolite sedute di forma sinusoidale.  
Struttura in acciaio cromato o laccato. Seduta  
imbottita in gomma poliuretanaica.  
Rivestimento in pelle o tessuto sfoderabile.  
Tavolino di collegamento  
in alluminio verniciato\_

Infinite approach curvilinear bench. By  
combining the elements together, it is  
possible to create unusual seating  
arrangements of sinusoidal form. Steel  
frame, chrome-plated or painted. Seat  
made of polyurethane foam. Removable  
leather or fabric covers. Connecting side table  
in painted aluminium\_



SNAKE\_Panca\_Bench\_design\_Matteo Scandola\_



149

Struttura in acciaio ricoperta in gomma poliuretana. Rivestimento in tessuto sfoderabile.

Steel frame covered with polyurethane foam. Removable fabric cover.



151

# MADIE E CONTENITORI SIDEBOARDS AND CABINETS



E' la credenza ALTEA in ebano l'indiscussa protagonista del living, attornita da elementi connotati da candore. Purezza e trasparenza come la libreria WAVY, reinterpretazione contemporanea dell'alveare. Il tavolo ovale LOTO, luminoso mix di acciaio e marmo, le sedie lineari WING CHAIR e le poltroncine intrecciate SAMOA\_

This is the ALTEA sideboard in ebony, the focal point of the living room, surrounded by elements of sheer whiteness. Purity and transparency like the WAVY bookcase, are a contemporary interpretation of a honeycomb. The oval LOTO table is a luminous mix of steel and marble, with linear WING CHAIRS and woven armchairs SAMOA\_



ALTEA\_Madia\_Sideboard\_design\_Giuseppe Bavuso\_

ALTEA reinterpreta in chiave contemporanea un elemento d'arredo classico: la vetrina. Le sue linee essenziali ed i dettagli in vetro sono volti ad esaltare la bellezza naturale dell'ebano, il suo colore intenso e la rigorosa venatura verticale.

Altea offers a contemporary interpretation of a classical element: the vitrine. Its essential lines and details in glass are conceived to exalt the natural beauty of the ebony, its intense colour, and dense vertical grain.





ALTEA\_Madia\_Sideboard\_

Candore lunare. Il bianco accompagna la credenza ALTEA, il tavolo LOTO con piano allungabile e le sedie WING CHAIR\_

Lunar glow. White brings it all the together – the ALTEA sideboard, the LOTO table with its extendable top, and the WING CHAIRS\_







ALTEA rispetta un rigoroso disegno formale, dove nulla è lasciato al caso. Questa lineare credenza in MDF laccato lucido è provvista di una luce interna che illumina gli oggetti posti nella teca in cristallo fumè. La vetrina è rivestita in cuoio. All'interno, dietro le due ante, trovano posto due cassetti ed un ripiano interno.

ALTEA is faithful to a rigorous formal design where nothing is left to chance. This linear sideboard in glossy lacquered MDF is equipped with integrated lighting to illuminate the objects in the grey glass display case. The inside is lined in hide. Inside, behind the two doors, are two drawers and an internal shelf.



EDOMADIA laccata bianca con base in acciaio cromato,  
tre cassetti superiori e tre scomparti inferiori.  
Personalizzabili con portabottiglie\_

White lacquered EDOMADIA with chrome-plated steel  
base, three upper drawers and three lower  
compartments. Personalized with the bottle rack\_



EDOMADIA\_Madia\_Sideboard\_

EDOMADIA, caratterizzata dalla maniglia di linea non convenzionale, è proposta nelle versioni con base in acciaio cromato o verniciato.

EDOMADIA, characterized by an unconventional handle, is available with chrome-plated or painted steel frame.





EDOMADIA importante nella forma,  
elegante nei colori\_

The EDOMADIA sideboard has a notable  
form and elegant colours\_





KUBIT\_Madia\_Sideboard\_

Espressione di alto design. KUBIT è qui proposta nella versione in laccato lucido bianco con piano in marmo bianco Michelangelo: è molto capiente, con ante laterali battenti angolari e quattro cassetti centrali.

High design: glossy white lacquered KUBIT with white Michelangelo marble top: it is very large, with angular side doors and four central drawers.



KUBIT, essenziale e di altissimo design, in  
laccato lucido o in rovere. Base in alluminio e  
piano in marmo o in pietra. Serena\_

KUBIT, minimalist sideboard in glossy  
lacquered wood or in oak. Aluminium base. Top  
in marble or Serena stone\_



Madia PORTLAND laccata lucida e tavolo LOTO con piano ovale,  
entrambi con piano in marmo bianco Michelangelo,  
sedie AXIA rivestite in cuoio nero\_

PORTLAND sideboard, glossy lacquered finish and LOTO table  
with oval top, both with tops in white Michelangelo marble,  
AXIA chairs upholstered in black hide\_



PORTLAND\_Madia\_Sideboard\_design\_Giuseppe Bavuso\_





PORTLAND\_Madia\_Sideboard\_

Le particolarità della madia PORTLAND sono tutte da scoprire: algida e rigorosa al primo sguardo, svela una mensola che è anche contenitore, provvista di quattro cassetti, e ampi vani protetti da ante scorrevoli. Il piano in marmo bianco Michelangelo esalta la riflessione della laccatura lucida.

The special features of the PORTLAND sideboard are not skin-deep: a bit cold and stand-offish at first glance, it reveals a shelf that is also a container with four drawers and spacious cabinets protected by sliding doors. The white Michelangelo marble top exalts the reflection of the glossy lacquer finish.



PIGRECO tavolo e PORTLAND madia in elegante  
abbinamento rovere grigio e pietra Serena.  
Sedie art. 844 (Alivar Museum)\_

PIGRECO table and PORTLAND sideboard in an elegant  
combination of grey oak and Serena stone.  
Chair art. 844 (Alivar Museum)\_



PORTLAND e la lucentezza dell'intramontabile laccato lucido nero.  
Ante scorrevoli e mensola superiore attrezzata con quattro cassetti\_

The fabulous glossy black PORTLAND with sliding doors and upper  
shelf with four drawers\_

PORTLAND\_ Madia\_Sideboard\_



179

MADIE CONTENITORI\_ SIDEBOARDS AND CABINETS\_



181

MADIE E CONTENITORI, SIDEBARDS AND CABINETS

DENVER\_Madia\_Sideboard\_design\_Giuseppe Bavuso



DENVER\_ Madia\_Sideboard\_

DENVER madia laccata lucido bianco, piani in pietra Serena e luce interna. WING LOUNGE CHAIR in pelle nera con struttura in acciaio cromato e tavolino DAYTONA\_

DENVER sideboard in white glossy lacquer, tops in Serena stone with an inside light. WING LOUNGE CHAIR in black leather with chrome-plated steel frame. DAYTONA side table\_



DENVER madia in rovere nero e pietra Serena. L'anta scorrevole garantisce un'apertura pratica che consente di ridurre gli ingombri e di ottenere un risultato estetico decisamente più gradevole.

DENVER sideboard in black oak and Serena stone. The sliding door is practical and makes it aesthetically pleasing.

CUBIC credenza laccata lucida\_

CUBIC sideboard, glossy lacquered\_

187

MADIE E CONTENITORI\_ SIDEBOARDS AND CABINETS\_

CUBIC\_Madia\_Sideboard\_design\_Enrico Cesana\_

Madia in MDF laccato lucido o opaco con due cassettoni esterni e due cassetti interni\_

Sideboard in glossy or matt lacquered MDF with two external drawers and two inner drawers\_







Sideboard in glossy or matt lacquered MDF with open, LED illuminated compartment. One large and two small drawers\_

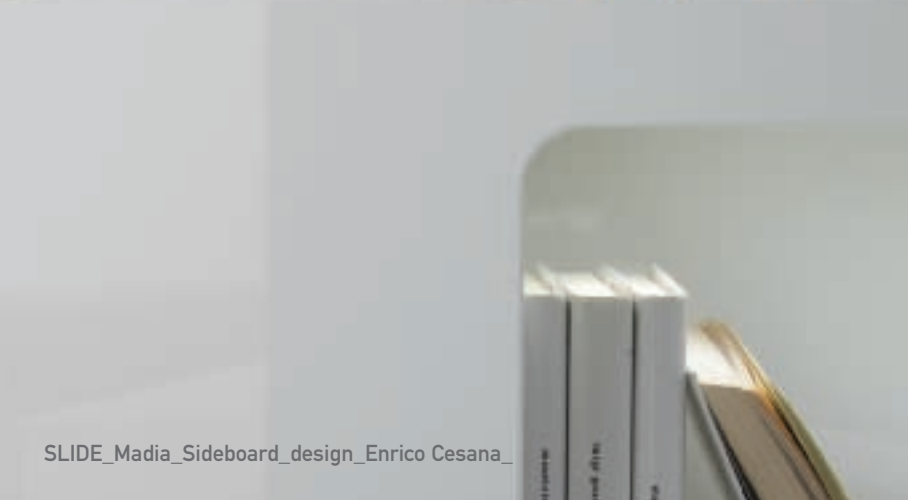

Madia in MDF laccato lucido o opaco con vano a giorno illuminato con LED. Un cassettoni e due cassetti\_





SLIDE. Madia in versione bianca laccata lucida\_

SLIDE. Sidebord in white glossy lacquered version\_







CONTAINER. Contenitore laccato bianco lucido.  
Poltrona art. 334 e poggiatesta art. 336  
(Alivar Museum) in pelle nera\_

CONTAINER. Cabinet in glossy white colour.  
Armchair art. 334 and ottoman art. 336 in black  
leather (Alivar Museum)\_

CONTAINER. Contenitore laccato lucido rosso vivo. Tavolo art. 769/7 (Alivar Museum)\_

CONTAINER. Cabinet in glossy red colour. Table art. 769/7 (Alivar Museum)\_

CONTAINER\_Contentitore\_Cabinet\_



199

MADIE E CONTENITORI\_SIDEBOARDS AND CABINETS\_



CONTAINER. Contenitore nella versione laccato bianco e rosso\_

CONTAINER cabinet in white and red lacquer\_



CONTAINER\_Contenitore\_Cabinet\_

CONTAINER. Contenitore laccato lucido nero.

CONTAINER. Cabinet in black glossy lacquer.









RADAR\_Tavolo\_Table\_

RADAR nella versione piano in marmo bianco Michelangelo, struttura in acciaio cromato e base in ghisa verniciata nera\_

RADAR with top in Michelangelo marble, frame in chrome-plated steel and base in black painted cast iron\_



Tavolo LOTO rettangolare allungabile, qui in versione  
aperta, con piano in lamellare di ebano,

Sedie WING chair nella versione in poliuretano rivestito in  
pelle e struttura in alluminio.

The LOTO rectangular table is extendable - here in the open  
version - with a top in ebony veneer,

WING Chairs in leather with aluminium frame.





Concretezza e illusione, questo il messaggio del tavolo LOTO, in versione rettangolare allungabile. Il piano, realizzato in lamellare di ebano, suggerisce robustezza e tangibilità, mentre il basamento in acciaio lucidato rimanda alla dimensione leggera e immateriale del sogno e delle emozioni. Abbinato alle sedie WING CHAIR\_

Concretezza and illusion, this is the message the LOTO table transmits in its extendable rectangular version. The top, made in ebony veneer, suggests strength and tangibility, while the base in polished steel evokes the lightweight and ethereal dimension of dreams and emotions. Shown with WING CHAIRS\_



Il tavolo LOTO ha una importante base in acciaio inox lucidato a specchio. Nella versione fissa il piano è ovale ed è disponibile in granito nero assoluto, marmo Calacatta oro, bianco Michelangelo e cristallizzato, in MDF laccato e in pietra acrilica bianca LG Hi-Macs\_

The LOTO table has a distinctive base in mirror-polished stainless steel. In the fixed version the top is oval and available in absolute black granite, Calacatta gold, white Michelangelo, and crystallized marbles, in lacquered MDF, or white LG High-Macs acrylic stone\_



213

XT tavolo con piano laccato lucido bianco e struttura in acciaio inox spazzolato. Sedlia art.704 (Alivar Museum)\_

XT table with glossy white lacquered top and legs in stainless steel. Chair art. 704 (Alivar Museum)\_





Essenziale e rigoroso il tavolo XT con piano in rovere.  
Sedie AXIA rivestite in cuoio nero\_

Simple and strong, the XT table with top in oak.  
AXIA chairs in black hide\_

BIG TABLE. Tavolo nella versione con  
piano in laccato laminato liquido e gambe  
in acciaio cromato. Sedie JAZZ\_

BIG TABLE with top in liquid laminated  
lacquer and chrome-plated steel legs.  
JAZZ chairs\_

219

BIG TABLE: Tavolo nella versione con piano laccato lucido nero.  
Sedie Art. 769/S (Alivar Museum) con cuscino  
di seduta in cavallino.

BIG TABLE: Table in the version with black  
glossy lacquered top. Chairs Art. 769/S (Alivar Museum) with  
seat covered in cow skin.



221



VERNISSAGE. Tavolo nella versione con piano  
laccato bianco. Sedie art. 355 (Alivar Museum)\_

VERNISSAGE. Table with white lacquered top.  
Chairs art. 355 (Alivar Museum)\_



Base in tubo di acciaio verniciato. Piano in legno laccato opaco  
o laccato laminato liquido. Spessore 6 cm.

Base made of painted steel tube. Matt lacquered wooden top or  
painted with a liquid laminate finish. Top thickness cm 6.



Tavolo VERNISSAGE nella versione con piano laccato bianco. Sedie art. 704 (Alivar Museum)\_

VERNISSAGE table with white lacquered top. Chairs art. 704 (Alivar Museum)\_

CUT tavolo nella versione tonda con base in acciaio cromato e piano in cristallo. ICE sedie in cuoio e gambe in acciaio cromato.

CUT table with chrome-plated steel base and glass top. ICE chairs in hide with chrome-plated legs.







CUT\_Tavolo\_Table\_

CUT tavolo nella versione tonda con base in acciaio laccato bianco e piano in marmo Michelangelo bianco. ICE sedie rivestite in cuoio e basamento in acciaio laccato bianco\_

CUT table with round top in white Michelangelo marble and white-painted steel base. ICE chairs in hide with white-painted steel legs\_



# TAVOLI TABLES

Base in acciaio cromato o laccato. Piano in cristallo, marmo  
o MDF laccato.

Chrome-plated or painted steel basement. Top in glass,  
marble or painted MDF.





CUT tavolo nella versione rettangolare con base  
in acciaio cromato e piano in cristallo.

ICE sedie con rivestite in cuoio e basamento  
in acciaio cromato. Sullo sfondo libreria SHELF.-SERVICE\_

CUT table with rectangular glass top and chrome-plated  
steel base. ICE chairs in hide with chrome-plated legs.

SHELF -SERVICE bookcase in the background.





239

Tavolo ovale. Struttura in metallo verniciato. Piano superiore in cristallo spessore 15 mm. Piano inferiore in rovere o laccato lucido\_

Oval table. Metal frame, painted. Upper top in glass 15 mm thick. Lower top in oak or glossy laquered wood\_



241

BIPLANO. Tavolo con piano superiore in cristallo e  
piano inferiore in legno laccato.  
Sedie SIMPLE CHAIR in pelle bianca\_

BIPLANO. Table with upper top in glass, lower top  
in lacquered wood.  
SIMPLE CHAIR in white leather\_



243

# SEDIE E SGABELLI CHAIRS AND STOOLS

AXIA\_Sedia\_Chair\_design\_Giuseppe Bavuso\_

Design e comfort si fondono in AXIA: la seduta e lo schienale, in cuoio e la struttura lineare, compongono una sedia dal gusto essenziale ed elegante.

Design and comfort are combined in AXIA: the seat and back are in hide and the frame is linear, making a chair that is simple but elegant.



245

SEDIE E SGABELLI\_CHAIRS AND STOOLS\_

Sedia AXIA con struttura in tubo di acciaio cromato o laccato.  
Rivestimento in cuoio. In questa pagina  
il cuoio bianco, nero e naturale.

AXIA chair with chrome-plated or painted steel frame.  
Hide cover. On this page the hide featured is  
in white, black or natural.





In WING CHAIR un intreccio in corda naturale o nera  
sono la seduta e lo schienale di questa sedia\_

The WING CHAIR has woven natural or black cord  
that forms the seat and back\_

TANGO, sedie impilabili nelle versioni nera o avorio.

TANGO. Stacking chairs in the black or ivory versions.



TANGO\_Sedia\_Chair\_design\_Archirivolto\_



251

SEDIE E SGABELLI\_CHAIRS AND STOOLS\_



JAZZ. Struttura in pressofusione di alluminio lucido o verniciato e monoscocca in coiniezione di nylon lucido, nelle varianti bianco, arancio, rosso, nero e avorio. Sedie impilabili. La caratteristica esilità dei bordi arrotondati, che esaltano l'elasticità, ne fanno un prodotto per chi ha scelto la qualità quotidiana del vivere e rifugge la finzione dell'apparire.

JAZZ. Structure in polished or painted aluminium die-cast frame and the single-seat, made of glossy injected nylon, in either white, orange, red, black or ivory. Stacking chairs. The typically slim-line of the rounded edges, enhance its versatility, and makes it a truly practical furnishing in today's modern settings.





LOLLIPOP. Sedia impilabile. La scocca, realizzata in materiale plastico Polimero San con l'esclusiva tecnica di bi-iniezione, può essere trasparente o coprente con finitura lucida, disponibile in sette colori diversi. La struttura può essere in tubo estruso di alluminio, lucido o verniciato bianco o nero, o in acciaio cromato o verniciato bianco o nero.

LOLLIPOP. Stacking chair. The shell is made of Polymer San plastic using an exclusive bi-injection technique, and may either be transparent or matt with glossy finishes, available in seven different colours. The frame can be in extruded anodised aluminium, polished or painted (black or white) or in chrome-plated or painted (black or white) steel tube.



# SEDIE E SGABELLI CHAIRS AND STOOLS

LOLLIPOP. Sedie nella versione con scocca in nero  
lucido coprente e struttura in acciaio cromato.  
Tavolo art. 459 (Alivar Museum)\_

LOLLIPOP. Chairs in glossy black seat and  
chrome-plated steel frame.  
Table art. 459 (Alivar Museum)\_

LOLLIPOP\_Sedia\_Chair\_



257

SEDIE E SGABELLI\_CHAIRS AND STOOLS\_



LOLLIPOP SL2 con struttura in tubo di acciaio cromato o verniciato (bianco o nero). LOLLIPOP SL3 con struttura in tondino di acciaio cromato o verniciato (bianco o nero).

LOLLIPOP SL2 with frame made of tubular steel, chrome-plated or painted (black or white). LOLLIPOP SL3 with frame made of steel wire, chrome-plated or painted (black or white).





SIMPLE CHAIR. Sedia nella versione con rivestimento in pelle bianco e nera. Gambe in piatto di acciaio cromato o laccato. Scocca in legno rivestita in gomma poliuretanica. Rivestimento in pelle o tessuto.



SIMPLE CHAIR covered in white and black leather. Chrome-plated or painted flat steel legs. Wooden shell covered in polyurethane foam. Leather or fabric covers.



Poltroncina ICE P. Gambe in acciaio cromato o verniciato. Scocca in legno rivestita in gomma poliuretana. Rivestimento in cuoio\_

ICE P Lounge chair. Chrome-plated or painted steel legs. Wooden shell covered with polyurethane foam. Hide covering\_



ICE S. Sedie rivestite in cuoio e  
basamento in acciaio cromato.

ICE S. Chairs covered in hide with  
chrome-plated steel legs.



265

Seduta in policarbonato trasparente o coprente con finitura lucida, disponibile in sette colori diversi. La sua struttura in acciaio cromato con meccanismo a gas permette una regolazione in altezza ed una rotazione totale per un utilizzo casa e contract\_

Seat made of polycarbonate either transparent or matt with glossy finish, available in seven different colours. Its chrome-plated steel frame, featuring a gas mechanism, permits height adjustment and total rotation for both domestic and contract settings.\_



267

KIRON. Sgabello nelle 5 varianti colore trasparenti.

KIRON. Barstool in 5 different colours.



269



# TAVOLINI SIDE TABLES

HARPA\_ Tavolino\_Side table\_design\_Giuseppe Bavuso\_

Tavolini HARPA nelle tre misure disponibili, qui in versione con struttura in acciaio laccato bianco e piano in pietra acrilica bianca LG HI-Macs.

HARPA coffee tables are available in three sizes. Seen here with a white painted steel base and top in LG HI-Macs white acrylic stone.





La ricerca e il design non dimenticano nemmeno gli elementi che, in genere, hanno una funzione puramente pratica. Il tavolino HARPA è unico nella sua linearità, e a renderlo tale basta il semplice incrocio che ne compone il basamento.

Research and design never forget elements that generally bear a purely practical function. HARPA coffee tables are unique in their lines, thanks to the simple intersection of three legs that make up the base.



Disponibile in tre modelli. HARPA è composto dalla base in acciaio cromato o laccato e dal piano circolare, nelle varianti in pietra acrilica bianca Alpine White LG Hi-Macs, marmo Marquinia nero, marmo bianco Michelangelo, marmo cristallizzato, lamellare di ebano o laccato lucido.

Available in three sizes. HARPA has a chrome-plated or painted base and a round top available in Alpine White LG Hi-Macs acrylic stone, black Marquinia marble, white Michelangelo marble, crystallized marble, ebony veneer, or glossy lacquered.





UP\_ Tavolino\_Side table\_design\_Giuseppe Bavuso\_

Utili e semplici accessori per i salotti Alivar, i tavolini UP sono qui proposti nella versione con piano in marmo.

Useful and simple accessories for Alivar sofas, UP tables are shown here with a marble top.



277

Tavolino DAYTONA, base in acciaio cromato o laccato.  
Piano in rovere o laccato lucido\_

DAYTONA table, chrome-plated or painted steel frame.  
Top in oak or glossy lacquered\_



279



CLUB\_ Tavolino\_Side table\_design\_Giuseppe Bavuso\_

Tavolino CLUB, base in acciaio cromato e piano in rovere o laccato lucido. Disponibile in tre diverse misure. I tavolini CLUB, nati per corredare i divani della collezione Alivar, diventano un particolare accattivante dell'area living se affiancati a due o più.

CLUB table, chrome-plated steel base and top in oak or glossy lacquered. Available in three different sizes. The CLUB side tables, specifically designed to match the Alivar lines, are captivating in the living area when placed in pairs or more.





BENCH\_Tavolino\_Side table\_design\_Giuseppe Bavuso\_

Tavolini BENCH in finitura laccato lucido o rovere con due cassetti contrapposti. Il taglio a 45° dei frontali è un segno inconfondibile della qualità ALIVAR, un mix tra qualità ed estetica\_

BENCH table in oak or glossy lacquered with two side drawers. The 45° cut of the frontal section is a sign of unique ALIVAR quality, a mix of craftsmanship and aesthetic beauty\_



Letto BLADE/B, gambe e cornice in acciaio cromato.  
Testata e giroletto imbottiti e rivestiti in pelle nera.  
Esprit comodino in MDF laccato lucido nero con base in acciaio cromato, poltroncina SAMOA e tavolino HARPA. Sul fondo art. 700, paravento in multistrato di frassino naturale, dalla collezione ALIVAR MUSEUM\_

BLADE/B bed with legs and frame in chrome-plated steel.  
Headboard and sides are padded and covered in black leather.  
Esprit bedside table in MDF lacquered in glossy black with chrome-plated steel base, SAMOA armchair, and HARPA table. In the background, Art. 700, screen in multilayer natural ash, from the ALIVAR MUSEUM collection\_





BLADE/B\_Letto\_Bed\_

La testata e il giroletto del letto BLADE sono imbottiti in gomma poliuretana e Dacron, e disponibili con rivestimento in pelle o in tessuto. Le basi e la cornice della testata sono realizzati in acciaio, laccato o cromato. Il letto BLADE è disponibile in due versioni: BLADE /A con testata alta e BLADE/B con testata bassa\_

The headboard and sides of the BLADE bed are padded in polyurethane foam and Dacron, available in either leather or fabric upholstery. The bases and the frame of the headboard are in either lacquered or chrome-plated steel. The BLADE bed is available in both versions: BLADE /A with high headboard and BLADE/B with low headboard\_



Letto BLADE/B, gambe e cornice in acciaio cromato.  
Testata e giroletto imbottiti e rivestiti in pelle bianca.  
ESPRIT comodini e comò in MDF laccati opaco bianco  
con base in acciaio cromato.

BLADE/B bed with legs and frame in chrome-plated steel.  
Headboard and sides are padded and covered in white leather.  
ESPRIT bedside tables and chest of drawers in MDF lacquered  
in matt white with chrome-plated steel base.



Letto BLADE/A, gambe e cornice in acciaio laccato. Testata e giroletto imbottiti e rivestiti in pelle bianca. ESPRIT comodino e settimanali in MDF laccato bianco con base in acciaio laccato, poltroncine SAMOA.

BLADE/A bed with legs and frame in painted steel. Headboard and sides are padded and covered in white leather. ESPRIT bedside table and high chest of drawers in white lacquered MDF with painted steel base, SAMOA armchairs.

291

Letto ECHO abbinato al settimanale e al comodino  
F\_JORD, poltroncina ATLANTA\_

ECHO bed combined with the F\_JORD high chest of  
drawers and bedside table and ATLANTA armchair\_

293



ECHO letto con cornice e gambe in acciaio, testata rivestita in pelle. FJORD comodini e comò abbinati con fianchi in noce Canaletto\_

ECHO bed with steel edge and legs, headboard covered in leather. FJORD bedside tables and chest of drawers with sides in Canaletto walnut\_



297

Letto FENG nella versione con rivestimento in tessuto. Comodino EDO\_

FENG bed with fabric cover. EDO bedside table\_



299



FENG\_Letto\_Bed\_

Le morbide forme di FENG con rivestimento in pelle scelgono il design essenziale del comodino FRAME. qui in versione rovere tinto wengé\_

The soft forms of FENG with leather upholstery combined with the simple design of FRAME bedside table. here in the wengé-stained oak version\_



301



Letto KENDO con il comodino della collezione EDO.  
Pouff ASCOT in pelle nera. All'esterno WING LOUNGE  
CHAIR versione da esterno con struttura verniciata e  
corda color bianco.

KENDO bed with EDO bedside table. ASCOT ottoman in  
black leather. Outside the WING LOUNGE CHAIR, outdoor  
version, with painted frame and white cord.



303



KENDO, letto con struttura in acciaio imbottita e testata con impuntura in pelle, predilige i complementi della collezione EDO.

KENDO bed with steel base, padding and headboard in leather. KENDO deserves the complements of the EDO collection.



PLAZA nella versione brown. Comodini e struttura in noce Canaletto coordinati alla testata imbottita in pelle. Poltroncina CLUB in pelle bianca.

PLAZA bed in brown. Bedside tables and base in Canaletto walnut with matching leather headboard. CLUB lounge chair in white leather.

307



PLAZA\_Letto\_Bed\_

Letto PLAZA attrezzabile con comodini in legno o laccati lucido.  
Testata imbottita con rivestimento in pelle o tessuto. In queste  
pagine le versioni classiche Black and White.

PLAZA bed that can be combined with wood or glossy lacquered  
bedside tables. Padded headboard with leather or fabric covers.  
These pages show the classic black and white versions.



309

Letto con testata capitonné. Struttura in acciaio rivestita in  
espanso. Base in tubo di acciaio verniciato alluminio goffrato o  
cromato. Rete con doghe in faggio. Disponibile in varie misure.

Bed with quilted headrest. Steel frame covered with polyurethan  
foam. Base in steel tube, painted embossed aluminium or  
chrome-plated. Beechwood slats. Available in different sizes.



BED BOSS medium. Letto in pelle.  
Tavolino art. 769/3 (Alivar Museum)\_

BED BOSS medium, covered in leather.  
Side table art. 769/3 (Alivar Museum)\_

313



BED BOSS LOW covered in leather\_



BED BOSS LOW letto in pelle\_



# COMPLEMENTI NOTTE BEDROOM COMPLEMENTS

ESPRIT\_Comò\_Chest of drawers\_design\_Giuseppe Bavuso\_

Tutta la linea dei complementi notte Esprit ha una forte connotazione minimalista, che si evidenzia nel design compatto ma, allo stesso tempo, leggero. La possibilità poi di scegliere tra una finitura lucida o, come in questo caso, opaca, permette di accentuarne o neutralizzarne l'effetto minimale.

The entire line of Esprit bedroom complements boasts distinctively minimalist lines, highlighted by a compact and lightweight design. The choice of glossy or, as in this case, matt finish either accentuates or neutralizes the minimalist effect.



317

COMPLEMENTI NOTTE\_BEDROOM COMPLEMENTS\_





ESPRIT\_Settimanale\_High chest of drawers\_

Cassettoni, settimanale e comodino compongono la gamma dei complementi notte ESPRIT, contraddistinti dal top con spigolo frontale smussato e dalle maniglie incassate. Ciascun elemento è disponibile in MDF laccato lucido o opaco con base in acciaio cromato o laccato.

Chest of drawers, high chest and bedside tables make up a range of ESPRIT bedroom complements, distinguished by the top with rounded front angle and flush handles. Each element is available in MDF lacquered glossy or matt with chrome-plated or painted steel base.



319

La collezione EDO propone settimanale, cassettoni e comodino in legno laccato lucido, opaco o rovere. In questa pagina l'elegante comò laccato lucido nero.

The EDO collection: chest of drawers, high chest and bedside table in oak, glossy or matt lacquered.

On this page: the elegant glossy black chest of drawers.



321

COMPLEMENTI NOTTE\_BEDROOM COMPLEMENTS\_

Nella collezione EDO le parti in legno tracciano una perfetta cornice, in continuità con la struttura in acciaio cromato.

In the EDO collection, the wood parts form a perfect framing for the chrome-plated steel base.



323



EDO\_Settimanale\_High chest of drawers\_

EDO, settimanale qui proposto nella versione in laccato lucido, un complemento night and day area\_

EDO high chest of drawers in glossy lacquered version, for both day or night area\_

Comodino F-JORD con fianchi in legno laccato lucido, top e cassetti rivestiti in cuoio bianco.

F-JORD bedside table with glossy white wooden sides. Clad in hide on top and drawers.



327



FJORD\_Settimanale\_High chest of drawers\_

La maniglia della collezione FJORD è un segno di classe disegnato dal rivestimento in cuoio su comodini, comò e cassettoni\_

The handle of the F.JORD collection is a sign of class. Clad in hide on top and drawers for the the bedside tables, chest of drawers and high chest\_



329

FJORD\_Settimanale\_High chest of drawers\_



FJORD settimanali con fianchi in noce Canaletto, top e cassetti rivestiti in cuoio. Più di un comodino, FJORD è quasi uno scrigno dove custodire gli oggetti più cari: il cassetto nasconde infatti un altro cassetto più piccolo.

FJORD high chest of drawers with sides in Canaletto walnut, top and drawers in hide. More than a bedside table, FJORD is like a jewellery box to keep your most dear possessions: the drawer in fact hides another smaller drawer.

FJORD\_Comodino\_Bedside table\_



331



FJORD\_Comò\_Chest of drawers\_

Il fianco in ebano, inconfondibile per la pregevole venatura, dona alla cassettera un'impronta unica, nel segno del pregio intramontabile dei materiali naturali\_

The sides in ebony, remarkable for its prestigious style, gives this chest of drawers a unique quality, a sign of the unsurpassable prestige of natural materials\_



333



FRAME una collezione di contenitori per la zona notte: comò,  
settimanali e comodini. in essenza o laccati, con fianchi in  
alluminio spazzolato\_

FRAME collection cabinets for the night area: chest of drawers,  
dresser and bedside tables in oak or glossy lacquered. Sides  
in brushed aluminium\_

FRAME\_Comò, Comodini e Settimanale\_  
Chest of drawers, bedside table and high chest of drawers\_design\_Giuseppe Bavuso\_



335

COMPLEMENTI NOTTE\_BEDROOM COMPLEMENTS\_

# COMPLEMENTI ACCESSORIES



FRAME COLLECTION\_ Specchio\_Mirror\_design\_Giuseppe Bavuso\_

Specchio. Profilo in alluminio spazzolato anodizzato finitura seta,  
con luce fluorescente interna\_

Mirror. "Silk finish" brushed anodised aluminium frame. Inside  
fluorescent light\_



337

COMPLEMENTI\_ACCESSORIES\_

Specchiera a parete con cornice in fusione di alluminio decorata a mano con decoro floreale a rilievo di provenienza rinascimentale\_

Framed wall mirror in cast aluminium with renaissance floreal hand-decoration in relief\_

LOOK AT ME\_Specchio\_Mirror\_  
design\_Bruno Rainaldi e Andrea Salvetti\_



339

COMPLEMENTI\_ACCESSORIES\_

LOOK AT ME. specchi singoli. Poltrone art. 334 in pelle nera  
(Alivar Museum)\_

LOOK AT ME single mirrors. Armchairs covered in black leather  
art. 334 (Alivar Museum)\_





QUADRUS\_Specchio\_Mirror\_design\_Bruno Rainaldi\_

Specchio composto da pannello in legno laccato con attacco a parete (sia verticale che orizzontale) e da quadri in lamiera laccati distanziati di 1 cm\_

Mirror made of a white wooden panel with wall attachment (vertical and horizontal) and squares in painted steel sheet at 1 cm\_





AB NORMAL\_Orologio\_Clock\_design\_Bruno Rainaldi\_



AB NORMAL orologio verniciato bianco\_

AB NORMAL clock, painted white\_



# PAGINE TECNICHE TECHNICAL SHEETS

Nelle pagine che seguono, tutti i disegni, le misure e le principali caratteristiche di tutti i prodotti del catalogo, per una consultazione ancora più chiara e globale di tutta la gamma delle varie collezioni.

The following pages contain all drawings, dimensions and main characteristics of all the products in the catalogue, making it easier to consult the entire range of the collections herein.

ALLVAR

## PANNELLI

## PANELS

Pagina\_Page 07

Pannellatura in MDF laccato lucido o opaco nei colori bianco 9016 o tortora 05.70. Illuminazione LED. Attacco a parete regolabile. Piedini regolabili.

Panel in MDF, glossy or matt lacquered, available in white 9016 or dove brown 05.70 colors. LED lighting. Adjustable wall-fixing. Adjustable feet.



Art. OSP110 / OSP110  
L/W 110 H 220 P/D 13.2  
W 43.3" H 86.6" D 5.2"

Art. OSP130 / OSP130  
L/W 130 H 220 P/D 13.2  
W 51.2" H 86.6" D 5.2"

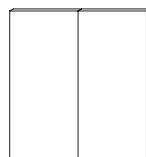

Art. OSP220 / OSP220  
L/W 220 H 220 P/D 13.2  
W 86.6" H 86.6" D 5.2"

Pannello come sopra predisposto per attacco TV al Plasma o LCD con foro passacavi e per supporto Vogel's EFW6345.

Panel as above to hang Plasma or LCD televisions with cable raceway, arranged also for Vogel's EFW6345 bracket.

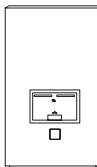

Art. OSPTV 110  
L/W 110 H 220 P/D 13.2  
W 43.3" H 86.6" D 5.2"

Art. OSPTV 130  
L/W 130 H 220 P/D 13.2  
W 51.2" H 86.6" D 5.2"

## BASAMENTI

## BASE

Basamento in MDF laccato lucido o opaco, nei colori bianco 9016 o tortora 05.70. Piedini regolabili.

Base in MDF, glossy or matt lacquered, available in white 9016 or dove brown 05.70 colors. Adjustable feet.

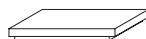

Art. OSB110  
L/W 110 H 12 P/D 55  
W 43.3" H 4.7" D 21.6"

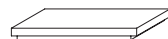

Art. OSB130  
L/W 130 H 12 P/D 55  
W 51.2" H 4.7" D 21.6"

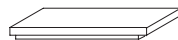

Art. OSB150  
L/W 150 H 12 P/D 55  
W 59" H 4.7" D 21.6"

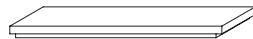

Art. OSB220  
L/W 220 H 12 P/D 55  
W 86.6" H 4.7" D 21.6"

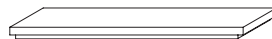

Art. OSB240  
L/W 240 H 12 P/D 55  
W 94.5" H 4.7" D 21.6"

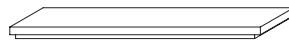

Art. OSB260  
L/W 260 H 12 P/D 55  
W 102.4" H 4.7" D 21.6"

## BASAMENTI PER PORTE SCORREVOLI

## BASES FOR SLIDING DOORS

Basamento predisposto per porta scorrevole in MDF laccato lucido o opaco, nei colori bianco 9016 o tortora 05.70. Piedini regolabili.

Base arranged for sliding doors, in MDF, glossy or matt lacquered, available in white 9016 or dove brown 05.70 colors. Adjustable feet.



Art. OSBS110  
L/W 110 H 12 P/D 55  
W 43.3" H 4.7" D 21.6"

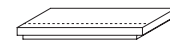

Art. OSBS130  
L/W 130 H 12 P/D 55  
W 51.2" H 4.7" D 21.6"

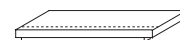

Art. OSBS150  
L/W 150 H 12 P/D 55  
W 59" H 4.7" D 21.6"

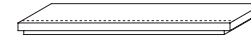

Art. OSBS220  
L/W 220 H 12 P/D 55  
W 86.6" H 4.7" D 21.6"



Art. OSBS240  
L/W 240 H 12 P/D 55  
W 94.5" H 4.7" D 21.6"

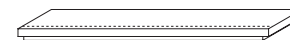

Art. OSBS260  
L/W 260 H 12 P/D 55  
W 102.4" H 4.7" D 21.6"

Binario. Rail.



Art. OSBA100

## MENSOLE

## SHELVES

Mensola in MDF laccato lucido o opaco nei colori bianco 9016, tortora 05.70 o in noce Canaletto. Illuminazione LED.

Shelf in MDF, glossy or matt lacquered available in white 9016, dove brown 05.70 or in Canaletto walnut. LED lighting.

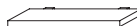

Art. OSR93 / OSR193  
L/W 93 H 5 P/D 27  
W 36.6" H 2" D 10.6"



Art. OSR113 / OSR113  
L/W 113 H 5 P/D 27  
W 44.5" H 2" D 10.6"



Art. OSR203 / OSR203  
L/W 203 H 5 P/D 27  
W 79.9" H 2" D 10.6"



## VETRINE

## CABINETS

Vetrina in MDF laccato lucido o opaco nei colori bianco 9016 o tortora 05.70. Anta in cristallo trasparente o fumé. Cornice in alluminio anodizzato bianco o naturale.

Cabinet in MDF, glossy or matt lacquered, available in white 9016 or dove brown 05.70. Door in glass either clear or smoke-grey. Aluminium edge either white, or natural.

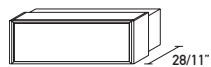

Art. OSV113  
L/W 113 H 38 P/D 28  
W 44.5" H 15" D 11"

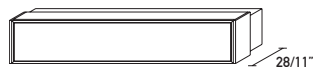

Art. OSV203  
L/W 203 H 38 P/D 28  
W 79.9" H 15" D 11"

Profondità interna. Inside depth. 23/9"

## CASSETTIERE DRAWER UNITS

Cassettone da appoggio in MDF laccato lucido o opaco nei colori bianco 9016, tortora 05.70 o in noce Canaletto con canalina passacavi in alluminio anodizzato.

Drawer unit in MDF, glossy or matt lacquered in white 9016, dove brown 05.70 or in Canaletto walnut with cables raceways in anodised aluminium.

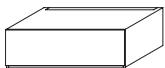

Art. OSC113A  
L/W 113 H 35 P/D 40  
W 44.5" H 13.8" D 15.7"



Art. OSC203  
L/W 203 H 35 P/D 40  
W 79.9" H 13.8" D 15.7"

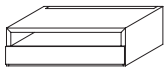

Art. OSC113C  
L/W 113 H 35 P/D 40  
W 44.5" H 13.8" D 15.7"

## ANTE SCORREVOLI SLIDING DOORS

Anta scorrevole in cristallo temperato trasparente o fumé, spessore 5 mm. completa di telaio in alluminio anodizzato naturale o verniciato bianco.

Sliding door made of tempered glass, clear or smoke-grey, 5 mm. thick complete with frame in anodised aluminium natural or painted white.

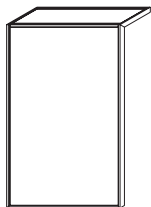

Art. OSAS110  
L/W 110 H 213.3 P/D 53.5  
W 43.3" H 84" D 21.1"

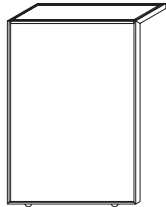

Art. OSAS130  
L/W 130 H 213.3 P/D 53.5  
W 51.2" H 84" D 21.1"

Binario superiore. Upper glide.

Art. OSBAS00

Binario superiore per anta scorrevole in alluminio anodizzato naturale, lunghezza massima mt. 6. Upper glide for sliding door in natural anodised aluminium, maximum length mt. 6.

## PORTA DVD

## DVD UNITS

Porta-DVD in alluminio anodizzato naturale o laccato bianco.

DVD unit made of anodised aluminium natural or white painted.

Porta DVD. DVD units.

Porta decoder. Decoder unit.



Art. OSDVD93  
L/W 93 H 22 P/D 16  
W 36.6" H 8.7" D 6.3"



Art. OSDEC93  
L/W 93 H 16 P/D 28  
W 36.6" H 6.3" D 11"

Art. OSDVD103  
L/W 103 H 22 P/D 16  
W 40.5" H 8.7" D 6.3"

Profondità interna. Inside depth. 14/5.5"

Art. OSDEC103  
L/W 103 H 16 P/D 28  
W 40.5" H 6.3" D 11"

Profondità interna. Inside depth. 26/10.2"

## PORTA DVD

## DVD UNITS

Elemento verticale porta-DVD in alluminio anodizzato naturale, laccato bianco o tortora 05.70.

Vertical DVD unit made of natural anodised aluminium or painted white or dove brown 05.70.

Porta DVD. DVD unit.

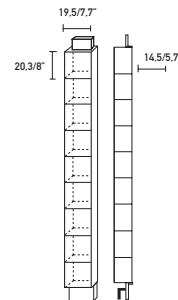

Art. OSDVD20V  
L/W 20 H 220 P/D 15.6  
W 7.9" H 86.6" D 6.1"

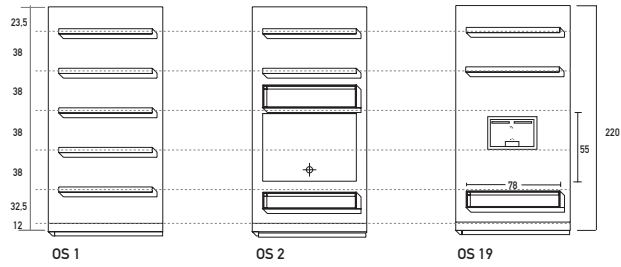

OS 1  
L/W 110 H 220  
W 43.3" H 86.7"

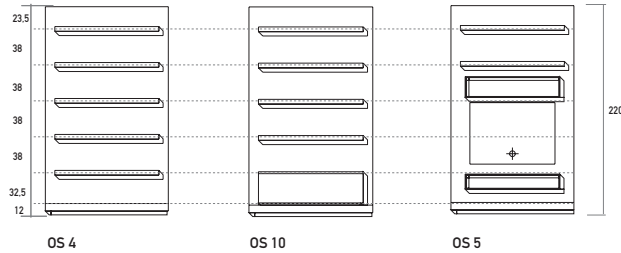

OS 4  
L/W 130 H 220  
W 51.2" H 86.7"

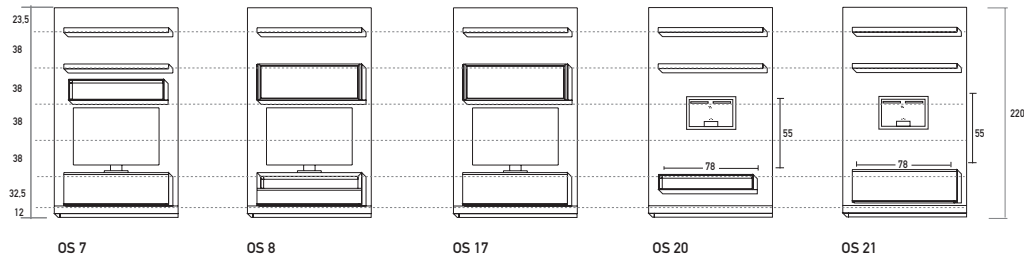

OS 7  
L/W 130 H 220  
W 51.2" H 86.7"

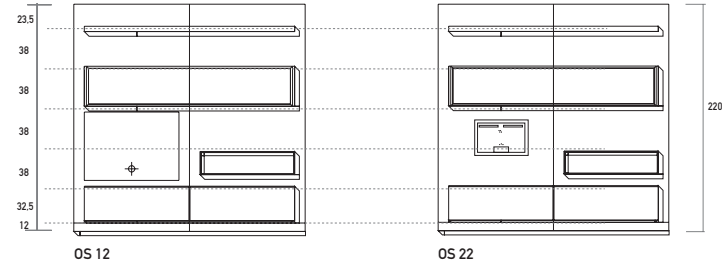

OS 12  
L/W 220 H 220  
W 86.7" H 86.7"

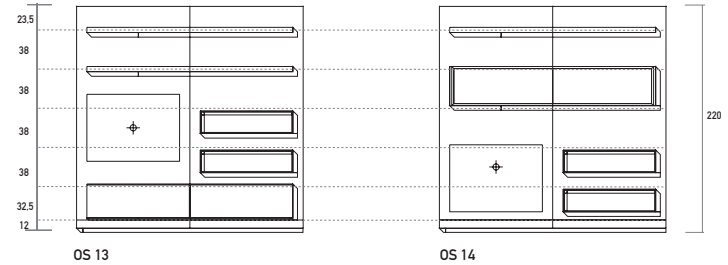

OS 13  
L/W 220 H 220  
W 86.7" H 86.7"

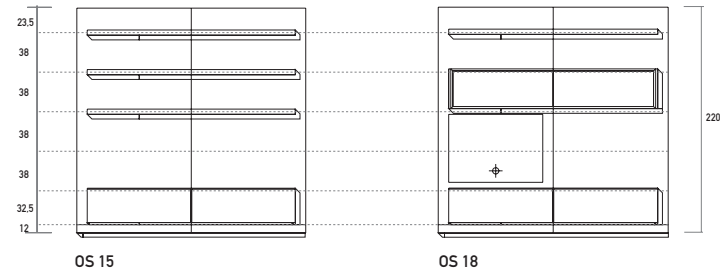

OS 15  
L/W 220 H 220  
W 86.7" H 86.7"

MENSOLE SHELVES

Pagina\_Page 19

Mensola con bordo in alluminio spazzolato anodizzato finitura seta o rivestito in rovere. Piano in cristallo satinato temperato spessore 5 mm, luce fluorescente interna.

Shelf. Edging frame in "Silk finish" brushed and anodised aluminium or covered with an oak veneer. Satin tempered glass top, 5 mm thick, with inside fluorescent light.

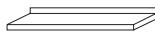

Art. A96  
L/W 96 H 5 P/D 30  
W 37,8" H 2" D 11,8"

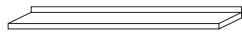

Art. A176  
L/W 176 H 5 P/D 30  
W 69,3" H 2" D 11,8"



Art. A144  
L/W 144 H 5 P/D 30  
W 56,7" H 2" D 11,8"

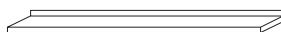

Art. A192  
L/W 192 H 5 P/D 30  
W 75,6" H 2" D 11,8"

BASE BASE

Base in lamiera di alluminio spazzolato anodizzato finitura seta con piedini regolabili.

Base made of "silk finish" brushed and anodised aluminium plate with adjustable feet.

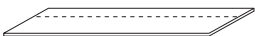

Art. G1  
L/W 176 H 4 P/D 65  
W 69,3" H 1,6" D 25,6"

MOBILI BASE BASE UNITS

Mobile base con fianchi in alluminio spazzolato anodizzato finitura seta, con piano in cristallo satinato temperato spessore 6 mm.

Base unit. Sides in "silk finish" brushed and anodised aluminium. Satin tempered glass top, 6 mm thick.

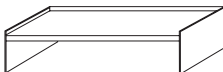

Art. B144  
L/W 144 H 28 P/D 65  
W 56,7" H 11" D 25,6"

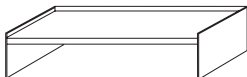

Art. B176  
L/W 176 H 28 P/D 65  
W 69,3" H 11" D 25,6"



Art. B192  
L/W 192 H 28 P/D 65  
W 75,6" H 11" D 25,6"

MOBILI BASE CON CASSETTI BASE UNITS WITH DRAWERS

Mobile base con canalina passacavi e fianchi in alluminio spazzolato anodizzato finitura seta. Piano e cassetti in legno disponibili in rovere o laccato lucido.

Base unit with "silk finish" brushed and anodised aluminium sides with cables raceway. Wooden top and drawers in oak or in glossy lacquered wood.

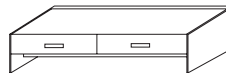

Art. C144  
L/W 144 H 28 P/D 65  
W 56,7" H 11" D 25,6"

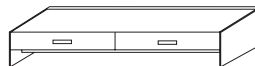

Art. C176  
L/W 176 H 28 P/D 65  
W 69,3" H 11" D 25,6"

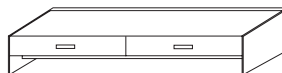

Art. C192  
L/W 192 H 28 P/D 65  
W 75,6" H 11" D 25,6"

MOBILI BASE CON CASSETTI BASE UNITS WITH DRAWERS

Mobile base con fianchi in alluminio spazzolato anodizzato finitura seta. Piano e cassetti in legno disponibili in rovere o laccato lucido.

Base unit with "silk finish" brushed and anodised aluminium sides. Wooden top and drawers in oak or in glossy lacquered wood.

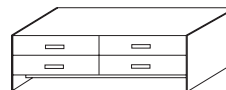

Art. D1144  
L/W 144 H 44 P/D 65  
W 56,7" H 17,3" D 25,6"

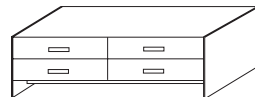

Art. D1176  
L/W 176 H 44 P/D 65  
W 69,3" H 17,3" D 25,6"

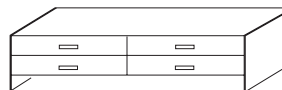

Art. D1192  
L/W 192 H 44 P/D 65  
W 75,6" H 17,3" D 25,6"

## FRAME COLLECTIONS

design Giuseppe Bavuso

### CONSOLLE PENSILI HANGING CONSOLES

Consolle pensile con fianchi e piano inferiore in alluminio spazzolato anodizzato finitura seta. Piano superiore e cassetti in legno disponibili in rovere o laccato lucido.

Hanging console with "silk finish" brushed and anodised aluminium sides and lower top. Upper wooden top and drawers in oak or in glossy lacquered wood.

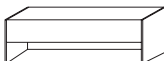

Art. E96  
L/W 96 H 26 P/D 32  
W 37.8" H 10.2" D 12.6"

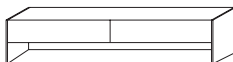

Art. E144  
L/W 144 H 26 P/D 32  
W 56.7" H 10.2" D 12.6"

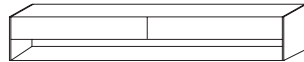

Art. E192  
L/W 192 H 26 P/D 32  
W 75.6" H 10.2" D 12.6"

### VETRINE PENSILI HANGING GLASS CUPBOARDS

Vetrina pensile con interno in legno laccato lucido. Fianchi in alluminio anodizzato. Top e anta a ribalta in cristallo.

Hanging glass cupboard in glossy lacquered wood. Anodised aluminium sides. Top and flapping door in glass.

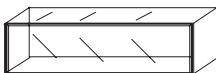

Art. V144  
L/W 144 H 40 P/D 32  
W 56.7" H 15.7" D 12.6"

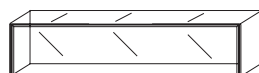

Art. V176  
L/W 176 H 40 P/D 32  
W 69.3" H 15.7" D 12.6"

### MOBILI PENSILE HANGING CABINET

Mobile pensile in MDF laccato lucido. Quattro ripiani interni in cristallo.

Hanging cabinet in glossy lacquered MDF. Four inside glass shelves.

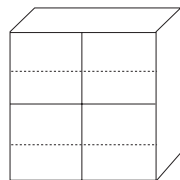

Art. E128  
L/W 128 H 128 P/D 31  
W 50.4" H 50.4" D 12.2"

### SPECCHI MIRRORS

Specchio. Profilo in alluminio spazzolato anodizzato finitura seta, con luce fluorescente interna.

Mirror: "Silk finish" brushed anodised aluminium frame. Inside fluorescent light.



Art. L1  
L/W 46 H 150 P/D 5  
W 18.1" H 59" D 2"

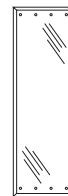

Art. L3  
L/W 52 H 180 P/D 5  
W 20.5" H 70.9" D 2"

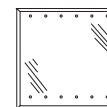

Art. L2  
L/W 86 H 86 P/D 5  
W 33.8" H 33.8" D 2"

### ELEMENTO PORTA TV/HI-FI TELEVISION/HI-FI UNIT

Elemento porta TV/HI-FI in legno disponibile in rovere, laccato lucido o laccato opaco con fori passacavi. Base in alluminio spazzolato anodizzato finitura seta, con piedini regolabili. Colonnine laterali porta DVD in alluminio. Mensola in alluminio per videoregistratore e decoder. Interruttore centrale per accensione. Luce fluorescente superiore di servizio.

Elemento porta TV/HI-FI con basamento in acciaio laccato alluminio.

Television/HI-FI unit with aluminium-painted steel basement.

Television/HI-FI unit in wood with an oak veneer or in glossy or matt lacquered wood. Arranged with cables raceway. Base made of "silk finish" brushed anodised aluminium plate with adjustable feet. Aluminium DVD rack on both sides. Shelf in aluminium for DVD/video recorder. Power switch. Fluorescent light.

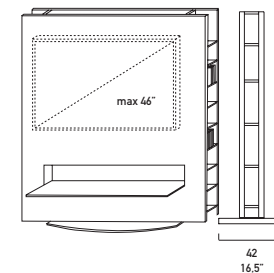

Art. HF2  
Pannello. Unit.  
L/W 144 H 160 P/D 14  
W 56.7" H 63" D 5.5"

Base. Base.  
L/W 105 P/D 42  
W 41.3" D 16.5"

Mensola. Shelf.  
L/W 105 P/D 29.5  
W 41.3" D 11.6"

42  
16.5"

Elemento porta TV/HI-FI con fori posteriori per fissaggio a parete. Basamento semiovale in acciaio laccato alluminio.

Television/HI-FI unit with aluminium painted steel basement. Arranged with holes on the back panel for wall-fixing.

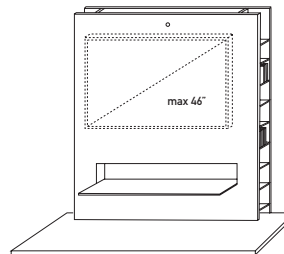

Art. HF1  
Pannello. Unit.  
L/W 144 H 160 P/D 14  
W 56.7" H 63" D 5.5"

Base. Base.  
L/W 176 P/D 65  
W 69.3" D 25.6"

Mensola. Shelf.  
L/W 105 P/D 29.5  
W 41.3" D 11.6"

30  
11.8"

Art. HF3  
Pannello. Unit.  
L/W 144 H 160 P/D 14  
W 56.7" H 63" D 5.5"

Base. Base.  
L/W 105 P/D 30  
W 41.3" D 11.8"

Mensola. Shelf.  
L/W 105 P/D 29.5  
W 41.3" D 11.6"

Composizione / Combination "A"  
3 x art. A 192  
1 x art. A 176  
1 x art. D1192  
1 x art. HF1

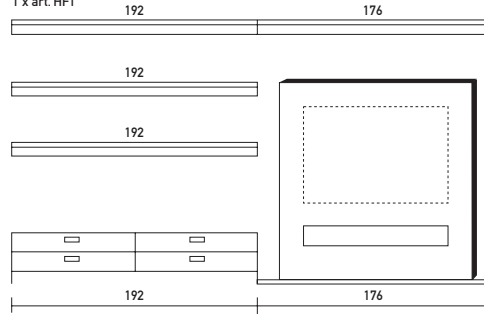

Composizione / Combination "D"  
3 x art. A 176  
2 x art. B 192  
2 x art. L 1

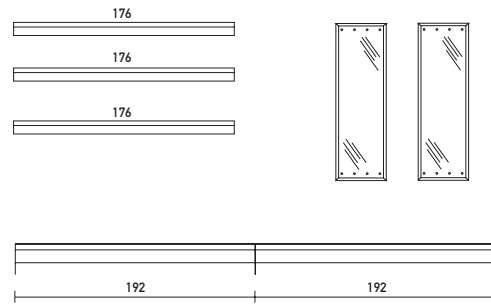

Composizione / Combination "E"  
3 x art. A 192  
2 x art. C 192  
1 x art. E 128

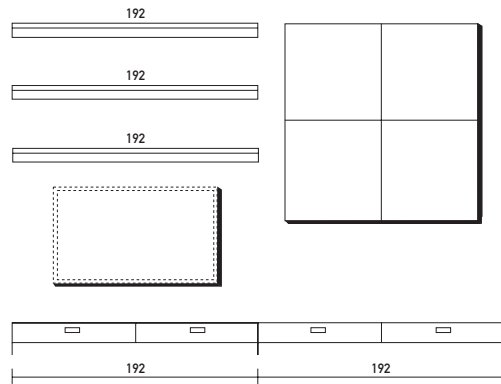

Composizione / Combination "G"  
2 x art. V 144  
2 x art. C 192  
3 x art. A 176

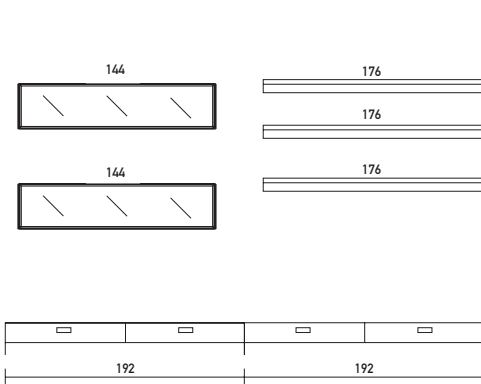

Elemento porta TV/HI-FI con fori passacavi. Pannello in legno laccato lucido, laccato opaco o in rovere. Colonnine laterali porta CD/DVD in alluminio. Mobiletto in alluminio verniciato per videoregistratore/decoder. Luce fluorescente superiore di servizio.

Television / HI-FI unit in wood with an oak veneer or in glossy or matt lacquered wood. Arranged with cables raceway. Aluminium CD/DVD rack on both sides. Shelves in painted aluminium for DVD/Video recorder. Fluorescent light.

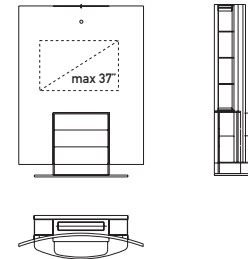

art. ETV 1  
L/W 100 H 149 P/D 35  
W 39.4" H 58.7" D 13.8"

359

HF2

design Giuseppe Bavuso

HF3

design Giuseppe Bavuso

Elemento porta TV/HI-FI in legno disponibile in rovere, laccato lucido o laccato opaco con fori passacavi. Basamento ovale in acciaio laccato alluminio. Colonnine laterali porta DVD in alluminio. Mensola in alluminio per videoregistratore e decoder. Interruttore centrale per accensione. Luce fluorescente superiore di servizio.

Television/HI-FI unit in wood with an oak veneer or in glossy or matt lacquered wood. Arranged with cables raceway. Basement in steel painted aluminium. Aluminium DVD rack on both sides. Shelf in aluminium for DVD/Video recorder. Power switch. Fluorescent light.

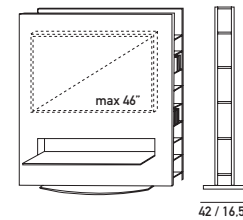

art. HF2  
Base. Base  
L/W 105 P/D 42  
W 41.3" D 16.5"

Pannello. Unit.  
L/W 144 H 160 P/D 14  
W 56.7" H 63" D 5.5"

Mensola. Shelf.  
L/W 105 P/D 29.5  
W 41.3" D 11.6"

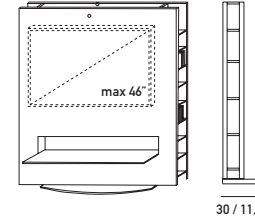

art. HF3  
Base. Base  
L/W 105 P/D 30  
W 41.3" D 11.8"

Pannello. Unit.  
L/W 144 H 160 P/D 14  
W 56.7" H 63" D 5.5"

Mensola. Shelf.  
L/W 105 P/D 29.5  
W 41.3" D 11.6"

Libreria in pietra acrilica bianca S28 Alpine white  L69 HI-MACS. Materiale composito di alto pregio, duraturo e resistente, non assorbente e non poroso. Ecologico, assolutamente impermeabile, non cambia colore nel tempo, è igienico perché non poroso. Schienale in melaminico bianco.

Bookshelf in S28 white acrylic stone  L69 HI-MACS. Materials used are of high quality, durability and resistance, as well as non absorbent and non porous. Ecological, absolutely water proof, the colour doesn't change over time, hygienic because it's not porous. Back in white Melamine.

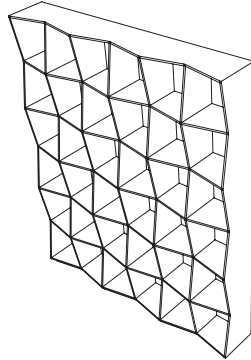

Esempi di composizioni  
Examples of combinations

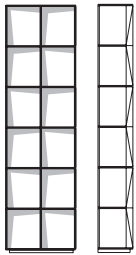

C1  
1 X art. EA2Z  
3 X art. EB2  
2 X art. EA2  
1 X art. EC2T

C1  
L/W 63 H 220.2 P/D 31  
W 24.8" H 86.7" D 12.2"

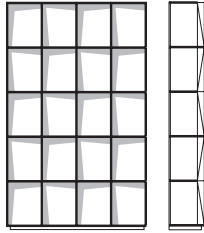

C2  
1 X art. EA4Z  
2 X art. EB4  
2 X art. EA4  
1 X art. ED4T

C2  
L/W 124 H 184.2 P/D 31  
W 48.8" H 72.5" D 12.2"

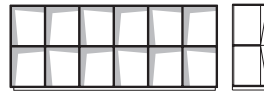

C3  
1 X art. EA6Z  
1 X art. EB6  
1 X art. EC6T

C3  
L/W 185 H 76.2 P/D 31  
W 72.8" H 30" D 12.2"

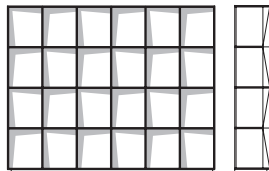

C4  
1 X art. EA6Z  
2 X art. EB6  
1 X art. EA6  
1 X art. EC6T

C4  
L/W 185 H 148.2 P/D 31  
W 72.8" H 58.3" D 12.2"

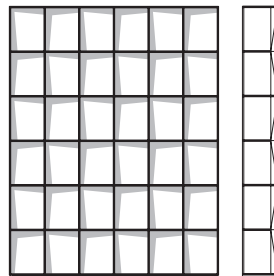

C5  
1 X art. EA6Z  
3 X art. EB6  
2 X art. EA6  
1 X art. EC6T

C5  
L/W 185 H 220.2 P/D 31  
W 72.8" H 86.7" D 12.2"

Libreria. Struttura in acciaio verniciato o cromato. Ripiani in legno disponibili nelle seguenti finiture: laccato lucido, laminato liquido, laccato opaco, rovere.

Bookcase. Frame in chrome-plated or painted steel. Wooden shelves available in the following finishes: glossy lacquered, liquid laminate, matt lacquered, oak.

Esempi di composizioni / Examples of combinations

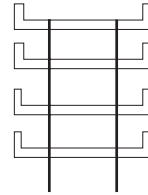

Art. 9204  
L/W 170 H 188 P/D 40  
W 66.9" H 74" D 15.7"

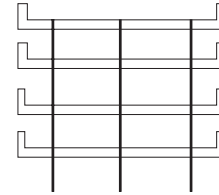

Art. 9205  
L/W 242 H 188 P/D 40  
W 95.3" H 74" D 15.7"

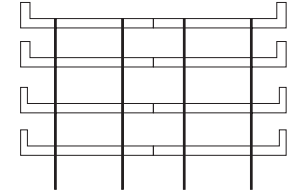

Art. 9200 (1 x art. 9100 SX / 1 x art. 9100 DX)  
L/W 330 H 188 P/D 40  
W 129.9" H 74" D 15.7"

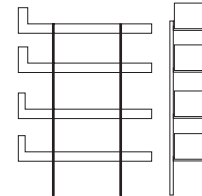

Art. 9100 DX - Art. 9100 SX  
L/W 165 H 188 P/D 40 SX/DX  
W 65" H 74" D 15.7" (left or right)

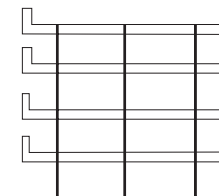

Art. 9206 DX - Art. 9206 SX  
L/W 237 H 188 P/D 40 DX/SX  
W 93.3" H 74" D 15.7" (left or right)

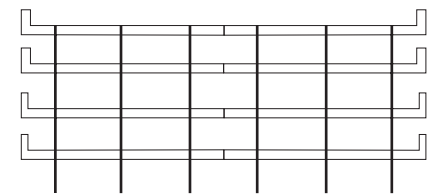

Art. 9207 (1 x art. 9206 SX / 1 x art. 9206 DX)  
L/W 474 P/D 40 H 188  
W 186.6" D 15.7" H 74"

Libreria componibile. Staffa di supporto per fissaggio al muro in acciaio laccato. Cavi autofilettanti in acciaio inox di varie misure. Accessori: ripiani e contenitori in rovere laccato lucido o opaco. I ripiani possono essere anche in cristallo temperato, trasparente o colorato.

Sectional bookcase. Support bracket for wall fixing in painted steel. Self-threading stainless steel cables in various sizes. Shelves and cabinets in oak glossy lacquered or matt lacquered. Shelves are available also in tempered clear glass or colored glass.

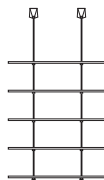

Composizione / Combination 5008  
L/W 120 H 218 P/D 44,5  
W 47,2" H 85,8" D 17,5"

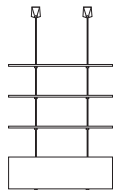

Composizione / Combination 5013  
L/W 120 H 228 P/D 44,5  
W 47,2" H 89,8" D 17,5"

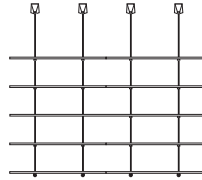

Composizione / Combination 5010  
L/W 240 H 218 P/D 44,5  
W 94,5" H 85,8" D 17,5"

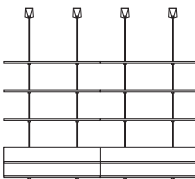

Composizione / Combination 5017  
L/W 240 H 218 P/D 44,5  
W 94,5" H 85,8" D 17,5"

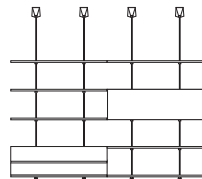

Composizione / Combination 5018  
L/W 240 H 218 P/D 44,5  
W 94,5" H 85,8" D 17,5"

## SURFACE

design Enrico Cesana

Libreria in Mdf laccato lucido o opaco.  
Bookcase in glossy or matt lacquered MDF.

Libreria bifacciale in Mdf laccato lucido o opaco.  
Double-faced bookcase in glossy or matt lacquered MDF.

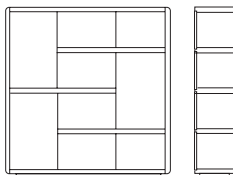

art. SUR 170  
L/W 170 H 175 P/D 40  
W 66,9" H 68,9" D 15,7"

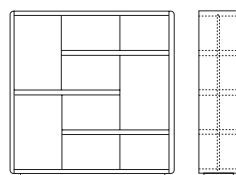

art. SUR 170 BIF  
L/W 170 H 175 P/D 40  
W 66,9" H 68,9" D 15,7"

Struttura in legno ricoperta in poliuretano indeformabile e fodera in tomana. Cuscini spalliera in piuma d'oca. Cuscini seduta in poliuretano indeformabile e fodera in tomana. Base in alluminio anodizzato lucido. Rivestimento in tessuto o pelle.

Wooden frame covered in non-deformable polyurethane foam with synthetic lining. Back cushions in down. Seat cushions made of non-deformable polyurethane foam with synthetic lining. Base in polished anodized aluminium. Fabric or leather covers.



Divani. Sofas.

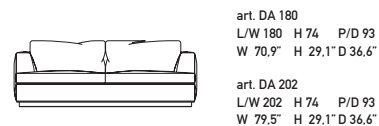

art. DA 180  
L/W 180 H 74 P/D 93  
W 70,9" H 29,1" D 36,6"

art. DA 224  
L/W 224 H 74 P/D 93  
W 88,2" H 29,1" D 36,6"

art. DA 202  
L/W 202 H 74 P/D 93  
W 79,5" H 29,1" D 36,6"

art. DA 246  
L/W 246 H 74 P/D 93  
W 96,8" H 29,1" D 36,6"

Elementi centrali. Central elements.



art. DAC 112  
L/W 112 H 74 P/D 93  
W 44,1" H 29,1" D 36,6"

art. DAC 123  
L/W 123 H 74 P/D 93  
W 48,4" H 29,1" D 36,6"

Elementi terminali destri o sinistri. Left or right ending elements.

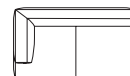

art. DAT 158 DX/SX  
L/W 158 H 74 P/D 93  
W 62,2" H 29,1" D 36,6"

art. DAT 180 DX/SX  
L/W 180 H 74 P/D 93  
W 70,9" H 29,1" D 36,6"

art. DAT 202 DX/SX  
L/W 202 H 74 P/D 93  
W 79,5" H 29,1" D 36,6"

art. DAT 224 DX/SX  
L/W 224 H 74 P/D 93  
W 88,2" H 29,1" D 36,6"

Chaise-longue con bracciolo destro o sinistro. Chaise-longue with left or right armrest.



art. DAD 112 DX/SX  
L/W 112 H 74 P/D 163  
W 44,1" H 29,1" D 64,2"



art. DAD 246 DX/SX  
L/W 246 H 74 P/D 93  
W 96,8" H 29,1" D 36,6"

Divani angolari destri o sinistri. Corner sofas, left or right.



art. DAA 224 DX/SX  
L/W 224 H 74 P/D 93  
W 88,2" H 29,1" D 36,6"

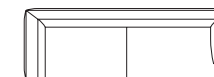

art. DAA 246 DX/SX  
L/W 246 H 74 P/D 93  
W 96,8" H 29,1" D 36,6"



art. DADA 246 DX/SX  
L/W 246 H 74 P/D 93  
W 96,8" H 29,1" D 36,6"

Elemento angolare destro o sinistro. Corner element, left or right.



art. DAA 123 DX/SX  
L/W 123 H 74 P/D 93  
W 48,4" H 29,1" D 36,6"

Pouff. Ottoman.



art. DAP 90  
L/W 90 H 39 P/D 93  
W 35,4" H 15,4" P/D 36,6"

Cuscino. Cushion.



art. 90361 - 9036  
L/W 43-53 P/D 43-53  
W 16,9"-20,8" D 16,9"-20,8"

Struttura in legno con cuscini imbottiti in poliuretano e piuma d'oca. Base e gambe in acciaio verniciato o cromato. Disponibile con bracciolo basso (B) e alto.

Wooden frame. Cushions in polyurethane foam and goose down. Steel base and legs, painted or chrome-plated. Available with low (B) or high armrest.

## Poltrona. Armchair.

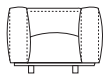
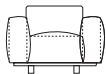
bracciolo alto  
high armrestbracciolo basso (B)  
low armrest (B)

51  
20"

art. PLB 98  
art. PLB 98 B  
L/W 98 H 65 P/D 90  
W 38,6" H 25,6" D 35,4"

## Elemento angolare. Corner element.



art. DLBA 108 DX/SX  
art. DLBA 108 B DX/SX  
L/W 108 H 65 P/D 90  
W 42,5" H 25,6" D 35,4"

## Elementi centrali. Central elements.



art. DLBC 89  
L/W 89 H 65 P/D 90  
W 35" H 25,6" D 35,4"

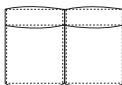

art. DLBC 140 art. DLBC 178  
L/W 140 H 65 P/D 90 L/W 178 H 65 P/D 90  
W 55,1" H 25,6" D 35,4" W 70,1" H 25,6" D 35,4"

Chaise-longue con bracciolo destro o sinistro.  
Chaise-longue with left or right armrest.

89 / 35"

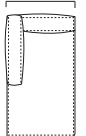

art. DLBD 89 DX/SX  
art. DLBD 89 B DX/SX  
L/W 89 H 65 P/D 159  
W 35" H 25,6" D 62,6"

108 / 42,5"

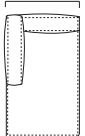

art. DLBD 108 DX/SX  
art. DLBD 108 B DX/SX  
L/W 108 H 65 P/D 159  
W 42,5" H 25,6" D 62,6"

## Divani. Sofas.

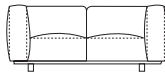

bracciolo alto. high armrest.

art. DLB 178 art. DLB 216  
art. DLB 178 B art. DLB 216 B  
L/W 178 H 65 P/D 90 L/W 216 H 65 P/D 90  
W 70,1" H 25,6" D 35,4" W 85" H 25,6" D 35,4"

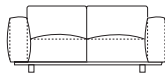

bracciolo basso (B). low armrest (B).

art. DLB 197 art. DLB 248  
art. DLB 197 B art. DLB 248 B  
L/W 197 H 65 P/D 90 L/W 248 H 65 P/D 90  
W 77,6" H 25,6" D 35,4" W 97,6" H 25,6" D 35,4"

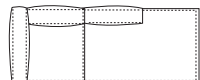

art. DLBD 248 DX/SX  
art. DLBD 248 B DX/SX  
L/W 248 H 65 P/D 90  
W 97,6" H 25,6" D 35,4"

## Elementi terminali destri o sinistri. Left or right ending elements.



art. DLBT 108 DX/SX  
art. DLBT 108 B DX/SX  
L/W 108 H 65 P/D 90  
W 42,5" H 25,6" D 35,4"

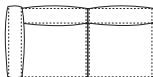

art. DLBT 159 DX/SX art. DLBT 178 DX/SX art. DLBT 197 DX/SX  
art. DLBT 159 B DX/SX art. DLBT 178 B DX/SX art. DLBT 197 B DX/SX  
L/W 159 H 65 P/D 90 L/W 178 H 65 P/D 90 L/W 197 H 65 P/D 90  
W 62,6" H 25,6" D 35,4" W 70,1" H 25,6" D 35,4" W 77,6" H 25,6" D 35,4"

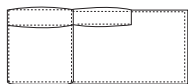

art. DLBT 229 DX/SX  
L/W 229 H 65 P/D 90  
W 89,8" H 25,6" D 35,4"

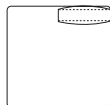
Chaise-longue, destra o sinistra.  
Chaise-longue, left or right.

art. CLLB 140 DX/SX  
L/W 140 H 65 P/D 140  
W 55,1" H 25,6" D 55,1"

## Pouff. Ottoman.



art. PFLB 89  
L/W 89 H 40 P/D 90  
W 35" H 15,7" D 35,4"

Cuscino in piuma.  
Cushion filled with down.

art. C42 art. C53  
L/W 42 P/D 42 L/W 53 P/D 53  
W 16,5" D 16,5" W 20,9" D 20,9"

Divano. Struttura in legno rivestita in poliuretano indeformabile e fodera in tomana. Cuscino seduta in gomma poliuretana e Dacron. Cuscino spalliera in piuma d'oca. Gambe in acciaio cromato o laccato.

Sofa. Wooden frame covered with non-deforming polyurethane foam with tomana lining. Seat cushion in polyurethane foam and Dacron. Back cushion in down. Chrome-plated or painted steel legs.

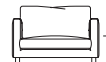
Poltrona.  
Armchair.41  
16,1"

art. DDO 82  
L/W 82 H 80 P/D 95  
W 32,3" H 31,5" D 37,4"

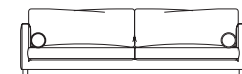
41  
16,1"

art. DDO 232  
L/W 232 H 80 P/D 95  
W 91,3" H 31,5" D 37,4"

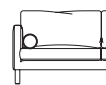
Divani.  
Sofas.41  
16,1"

art. DDO 192  
L/W 192 H 80 P/D 95  
W 75,6" H 31,5" D 37,4"

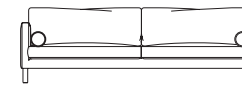
41  
16,1"

art. DDO 252  
L/W 252 H 80 P/D 95  
W 99,2" H 31,5" D 37,4"

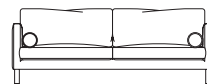
41  
16,1"

art. DDO 212  
L/W 212 H 80 P/D 95  
W 83,5" H 31,5" D 37,4"

Pouff.  
Ottoman.

art. PDO 95  
L/W 95 H 40 P/D 95  
W 37,4" H 15,7" D 37,4"

## HAERO

## design Giuseppe Bavuso

Struttura in legno ricoperta in gomma poliuretana e dacron. Base in trafilato di alluminio spazzolato. Rivestimento in tessuto o pelle.

Wooden frame covered in polyurethane foam and dacron. Base in brushed aluminium. Fabric or leather covers.

## Divani. Sofas.

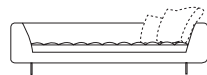

art. D1  
L/W 173 H 64 P/D 97  
W 68,1" H 25,2" D 38,2"

art. D2  
L/W 209 H 64 P/D 97  
W 82,3" H 25,2" D 38,2"

art. D3  
L/W 245 H 64 P/D 97  
W 96,4" H 25,2" D 38,2"

## Dormeuse

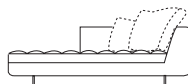

art. D4 DX/SX  
L/W 200 H 64 P/D 87,5  
W 78,7" H 25,2" D 34,4"

## Pouff. Ottoman.

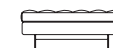

art. D10  
L/W 105 H 40 P/D 105  
W 41,3" H 15,7" D 41,3"

## Letto. Day bed.



art. D9  
L/W 192,5 H 59 P/D 87,5  
W 75,8" H 23,2" D 34,4"



art. C42 art. C53  
L/W 42 P/D 42 L/W 53 P/D 53  
W 16,5" D 16,5" W 20,9" D 20,9"



Struttura in legno ricoperta in gomma poliuretana e dacron. Base in alluminio spazzolato, anodizzato finitura seta. Rivestimento in tessuto o pelle. Cuscini in piuma.

Wooden frame covered with polyurethane foam and dacron. Base in "Silk finish" brushed anodised aluminium. Fabric or leather covers. Cushions in down.

## Divani. Sofas.

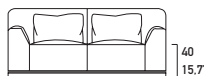

art. DM 179  
L/W 179 H 72 P/D 95  
W 70.5" H 28.3" D 37.4"

art. DM 201  
L/W 201 H 72 P/D 95  
W 79.1" H 28.3" D 37.4"

art. DM 223  
L/W 223 H 72 P/D 95  
W 87.8" H 28.3" D 37.4"

art. DM 243  
L/W 243 H 72 P/D 95  
W 95.7" H 28.3" D 37.4"

## Elementi terminali destri o sinistri. Left or right ending elements.

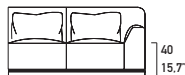

art. DM 157 T DX/SX  
L/W 157 H 72 P/D 95  
W 61.8" H 28.3" D 37.4"

art. DM 179 T DX/SX  
L/W 179 H 72 P/D 95  
W 70.5" H 28.3" D 37.4"

art. DM 201 T DX/SX  
L/W 201 H 72 P/D 95  
W 79.1" H 28.3" D 37.4"

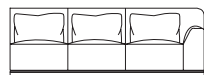

art. DM 223 T DX/SX  
L/W 223 H 72 P/D 95  
W 87.8" H 28.3" D 37.4"

## Elementi centrali. Central elements.

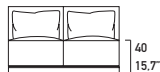

art. DM 135 C  
L/W 135 H 72 P/D 95  
W 53.1" H 28.3" D 37.4"

art. DM 157 C  
L/W 157 H 72 P/D 95  
W 61.8" H 28.3" D 37.4"

art. DM 179 C  
L/W 179 H 72 P/D 95  
W 70.5" H 28.3" D 37.4"

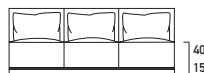

art. DM 201 C  
L/W 201 H 72 P/D 95  
W 79.1" H 28.3" D 37.4"

## Dormeuse. Chaise-longue.



art. DMD 89  
L/W 89 H 72 P/D 174  
W 35" H 28.3" D 68.5"

## Dormeuse con bracciolo, destra o sinistra. Chaise-longue with left or right armrest.



art. DMD 111 DX/SX  
L/W 111 H 72 P/D 174  
W 43.7" H 28.3" D 68.5"

## Elemento angolare. Corner element.



art. DM 105 A  
L/W 105 H 72 P/D 105  
W 41.3" H 28.3" D 41.3"

## Pouff. Ottoman.



art. DMP 97  
L/W 97 H 40 P/D 97  
W 38.2" H 15.7" D 38.2"

Divano. Base in rovere. Spalliera reclinabile in acciaio e struttura in legno rivestite in gomma poliuretana e dacron. Cuscini seduta in gomma poliuretana e dacron. Rivestimento in pelle o tessuto.

Sofa. Basement in oak. Wooden frame and reclining steel back, both covered in polyurethane foam and dacron. Back with reclining steel frame. Seat cushions in polyurethane foam and dacron. Leather or fabric covers.

## Divani. Sofas.

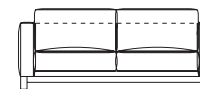
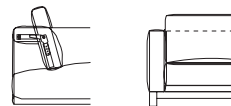

art. DD 180  
L/W 180 H 63/80 P/D 103  
W 70.9" H 24.8"/31.5" D 40.5"

art. DD 204  
L/W 204 H 63/80 P/D 103  
W 80.3" H 24.8"/31.5" D 40.5"

art. DD 228  
L/W 228 H 63/80 P/D 103  
W 89.8" H 24.8"/31.5" D 40.5"

art. DD 252  
L/W 252 H 63/80 P/D 103  
W 99.2" H 24.8"/31.5" D 40.5"

## Cuscino in piuma. Cushion filled with down.



art. C62  
L/W 42 P/D 42  
W 16.5" D 16.5"

art. C53  
L/W 53 P/D 53  
W 20.9" D 20.9"

## SBEND

## design Bruno Rainaldi

Poltrona, divani e pouf. Struttura in legno ricoperta in gomma poliuretana e dacron. Rivestimento in tessuto sfoderabile o pelle. Piedi in acciaio verniciato.

Armchair, sofas and ottoman. Wooden frame covered in polyurethane foam and dacron. Leather or fabric covers. (Removable fabric covers). Painted steel feet.

## Poltrona. Armchair.

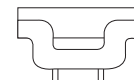

art. 9061  
L/W 120 P/D 85 H 81  
W 47.2" D 33.5" H 31.9"

## Divani. Sofas.

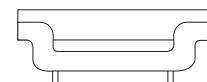

art. 9062  
L/W 180 P/D 85 H 81  
W 70.9" D 33.5" H 31.9"

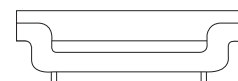

art. 9063  
L/W 210 P/D 85 H 81  
W 82.7" D 33.5" H 31.9"

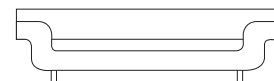

art. 9064  
L/W 240 P/D 85 H 81  
W 94.5" D 33.5" H 31.9"

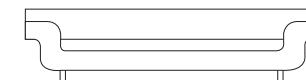

art. 9065  
L/W 270 P/D 85 H 81  
W 106.3" D 33.5" H 31.9"

## Panca. Bench.

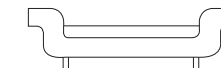

art. 9066  
L/W 190 P/D 60 H 62  
W 74.8" D 23.6" H 24.4"

## Dormeuse.

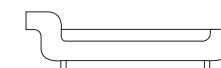

art. 9067  
L/W 210 P/D 70 H 62  
W 82.7" D 27.5" H 24.4"

## Pouff. Ottoman.



art. 9094P  
L/W 107 P/D 107 H 43  
W 42.1" D 42.1" H 16.9"

## Cuscini. Cushions.



art. 90361 - 9036  
L/W 43-53 P/D 43-53  
W 16.9"-20.8" D 16.9"-20.8"

## BOSS

design Bruno Rainaldi

DIVANO

SOFA

Pagina\_Page 97

Poltrona, divano. Struttura in acciaio rivestita in poliuretano. Base in tubo di acciaio verniciato o cromato.

Armchair, sofa. Steel frame covered with polyurethane foam. Base in steel tube, painted or chrome-plated.

Poltrona. Armchair.



art. 9005  
L/W 123 P/D 75 H 80  
W 48.4" D 29.5" H 31.5"

Divani. Sofas.

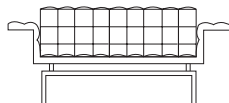

art. 9002  
L/W 195 P/D 75 H 80  
W 76.8" D 29.5" H 31.5"

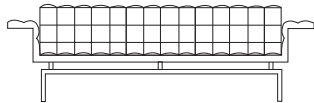

art. 9083  
L/W 270 P/D 75 H 80  
W 106.3" D 29.5" H 31.5"

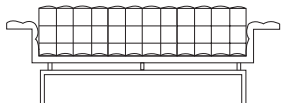

art. 9003  
L/W 240 P/D 75 H 80  
W 94.5" D 29.5" H 31.5"

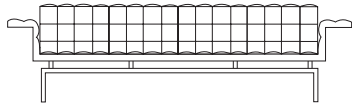

art. 9004  
L/W 300 P/D 75 H 80  
W 118.1" D 29.5" H 31.5"

## BUDDY BOSS

design Bruno Rainaldi

DIVANO

SOFA

Pagina\_Page 101

Poltroncina e divanetto. Struttura in acciaio rivestita in poliuretano. Gambe in tubo di acciaio cromato o verniciato.

Armchair and sofa. Steel frame covered with polyurethane foam. Chrome-plated or painted steel feet.

Poltroncina. Armchair.

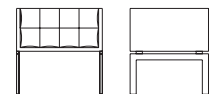

art. 9241  
L/W 71 H 75 P/D 65  
W 28" H 29.5" D 25.6"

Divanetto. Sofa.

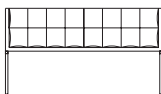

art. 9242  
L/W 127 H 75 P/D 65  
W 50" H 29.5" D 25.6"

## CLUB

design Giuseppe Bavuso

POLTRONA

ARMCHAIR

Pagina\_Page 105

Poltroncina. Struttura in acciaio rivestita in espanso schiumato a caldo. Rivestimento in pelle o fintapelle. Gambe in acciaio cromato.

Armchair. Steel frame covered in polyurethane foam. Leather or synthetic leather covers. Chrome-plated steel legs.

Poltrona. Armchair.



art. PC1  
L/W 76.8 H 60.5 P/D 78.5  
W 30.2" H 23.8" D 30.9"

## ATLANTA

design Giuseppe Bavuso

POLTRONA

ARMCHAIR

Pagina\_Page 109

Poltrona con braccioli (art. D7/B), senza braccioli (art. D7) e pouff (art. D8). Struttura in acciaio cromato o verniciato. Rivestimento imbottito e trapuntato.

Armchair (art. D7/B), lounge chair (art. D7) and ottoman (art. D8). Frame in chrome-plated or painted steel. Quilted cover.

Poltrona con braccioli. Armchair.



art. D7/B  
L/W 69 H 61 P/D 90  
W 27.2" H 24" D 35.4"

Poltrona senza braccioli. Lounge chair.



art. D7  
L/W 69 H 61 P/D 90  
W 27.2" H 24" D 35.4"

Pouff. Ottoman.



art. D8  
L/W 69 H 36 P/D 44.8  
W 27.2" H 14.2" D 17.6"

## WING LOUNGE CHAIR

design Giuseppe Bavuso

POLTRONCINA LOUNGE CHAIR

Pagina\_Page 115

art. PW1

Poltroncina. Seduta e spalliera in poliuretano stampato e rivestito in fintapelle, pelle o cavallino. Struttura in acciaio tagliata al laser con finiture: cromo, nickel nero, laccato bianco, nero o alluminio.

art. PW2

Poltroncina. Seduta e spalliera in corda intrecciata colore naturale, bianca o nera. Struttura in acciaio tagliata al laser con finiture: cromo, nickel nero, laccato bianco, nero o alluminio.

art. PW3

Poltroncina per esterno. Seduta in cordino lavabile composto da filato (nastro) in film poleofinico nei colori bianco, nero o naturale. Struttura in acciaio tagliato al laser laccato bianco, nero o alluminio.

art. PW1

Lounge chair. Seat and back made of moulded polyurethane foam covered in synthetic leather, leather or cow skin. Laser-cut steel frame with choice of finishes: chrome, black nickel, white, black or aluminium lacquered.

art. PW2

Lounge chair. Seat and back made of woven cord in natural, white or black colour. Laser-cut steel frame with choice of finishes: chrome, black nickel, white, black or aluminium lacquered.

art. PW3

Lounge chair for outdoor use. Seat in washable cord consisting of yarn (strip) made of polyolefinic film in the colours: white, black or natural. Frame made of laser-cut steel, lacquered white, black or aluminium.

Poltroncina. Lounge chair.



art. PW1  
L/W 70 H 70 P/D 74  
W 27.5" H 27.5" D 29.1"

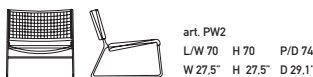

art. PW2  
L/W 70 H 70 P/D 74  
W 27.5" H 27.5" D 29.1"

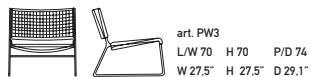

art. PW3  
L/W 70 H 70 P/D 74  
W 27.5" H 27.5" D 29.1"

## WING STOOL

design Giuseppe Bavuso

SGABELLO OTTOMAN

Pagina\_Page 115

art. SGW1

Pouff. Seduta in poliuretano stampato e rivestito in fintapelle, pelle o cavallino. Struttura in acciaio tagliata al laser con finiture: cromo, nickel nero, laccato bianco, nero o alluminio.

art. SGW2

Pouff. Seduta in corda intrecciata color naturale bianca o nera. Struttura in acciaio tagliata al laser con finiture: cromo, nickel nero, laccato bianco, nero o alluminio.

art. SGW3

Sgabello per esterno. Seduta in cordino lavabile composto da filato (nastro) in film poleofinico nei colori bianco, nero o naturale. Struttura in acciaio tagliato al laser laccato bianco, nero o alluminio.

art. SGW1

Ottoman. Seat made of moulded polyurethane foam covered in synthetic leather, leather or cow skin. Laser-cut steel frame with choice of finishes: chrome, black nickel, white, black or aluminium lacquered.

art. SGW2

Ottoman. Seat made of woven cord in natural, white or black colour. Laser-cut steel frame with choice of finishes: chrome, black nickel, white, black or aluminium lacquered.

art. SGW3

Ottoman for outdoor use. Seat in washable cord consisting of yarn (strip) made of polyolefinic film in the colours: white, black or natural. Frame made of laser-cut steel, lacquered white, black or aluminium.

Pouff. Ottoman.

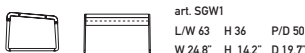

art. SGW1  
L/W 63 H 36 P/D 50  
W 24.8" H 14.2" D 19.7"



art. SGW2  
L/W 63 H 36 P/D 50  
W 24.8" H 14.2" D 19.7"

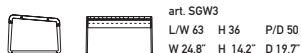

art. SGW3  
L/W 63 H 36 P/D 50  
W 24.8" H 14.2" D 19.7"

## SAMOA

design Giuseppe Bavuso

POLTRONCINA LOUNGE CHAIR

Pagina\_Page 121

Poltroncina. Struttura in tubolare di acciaio cromato o laccato. Seduta e spalliera in poliuretano schiumato a caldo e rivestito in pelle, fintapelle o cavallino.

Lounge Chair Tubular steel frame, chrome-plated or painted. Seat and back in moulded polyurethane foam, covered in leather, synthetic leather or cow hide.



art. PS 1  
L/W 70 H 66 P/D 78  
W 27.6" H 26" D 30.7"

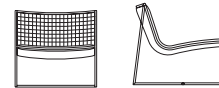

art. PS 1 I (intrecciata / woven)  
L/W 70 H 66 P/D 78  
W 27.6" H 26" D 30.7"

371

## SIMPLE ARMCHAIR

design Roberto Lazzeroni

POLTRONCINA ARMCHAIR

Pagina\_Page 127

Poltrona. Struttura in tubo d'acciaio cromato o verniciato. Seduta e spalliera in gomma poliuretanicca e dacron.

Armchair. Chrome-plated or painted steel frame. Seat and back made of polyurethane foam and dacron.

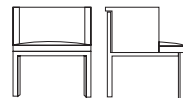

art. 7004  
L/W 61 H 74.5 P/D 65  
W 24" H 29.3" D 25.6"

## ICE P

design Alessandro Andreucci e Christian Hoisl

POLTRONCINA ARMCHAIR

Pagina\_Page 263

Poltroncina. Gambe in acciaio cromato o verniciato. Scocca in legno rivestita in gomma poliuretanicca. Rivestimento in cuoio.

Lounge chair. Chrome-plated or painted steel legs. Wooden shell covered with polyurethane foam. Hide covering.



art. ICE P  
L/W 62 H 68 P/D 70  
W 24.4" H 26.8" D 27.5"

## INTERNOS

design Bruno Rainaldi

POLTRONCINA ARMCHAIR

Pagina\_Page 129

Poltroncina. Struttura in legno ricoperta in gomma poliuretana e dacron. Rivestimento in tessuto o pelle. Piedi cromati.

Armchair. Wooden frame covered in polyurethane foam and dacron. Leather or fabric covers. Chrome-plated feet.

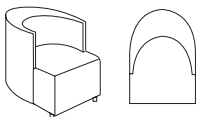

art. 9085  
L/W 67 H 70 P/D 80  
W 26.3" H 27.5" D 31.5"

## FORTUNA

design Pietro Arosio

POLTRONA ARMCHAIR

Pagina\_Page 133

Poltrona. Struttura in legno massello ricoperta in poliuretano e dacron. Rivestimento in pelle o tessuto.

Armchair. Frame in solid wood covered in moulded polyurethane foam and dacron. Leather or fabric covers.



art. 4025  
L/W 85 H 94 P/D 87  
W 33.5" H 37" D 34.2"

## LOLLY

design Daniele Lo Scalzo Moscheri

POLTRONA ARMCHAIR

Pagina\_Page 137

Poltrona. Struttura in piatto di acciaio cromato o verniciato. Cuscino seduta in poliuretano e dacron rivestito in tessuto o pelle. Spalliera in cuoio.

Armchair. Frame made of painted or chrome-plated flat steel. Upholstered seat cushion covered in leather or fabric. Back in hide.



art. 4075  
L/W 64 H 79 P/D 68  
W 25.2" H 31.1" D 26.8"

## BOSS

design Bruno Rainaldi

PANCA BENCH

Pagina\_Page 145

Panca. Struttura in acciaio rivestita in espanso. Base in tubo di acciaio verniciato o cromato.

Bench. Steel frame covered with polyurethane foam. Base in steel tube, painted or chrome-plated.

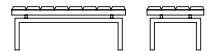

art. 9006  
L/W 120 P/D 60 H 43  
W 47.2" D 23.6" H 16.9"

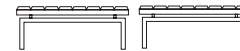

art. 9006/B  
L/W 120 P/D 120 H 43  
W 47.2" D 47.2" H 16.9"



art. 9006/A  
L/W 160 P/D 60 H 43  
W 63" D 23.6" H 16.9"

## TECH

design Matteo Scandola

PANCA BENCH

Pagina\_Page 141

Panca. Struttura in acciaio cromato o verniciato. Seduta imbottita in gomma poliuretana. Rivestimento in pelle o tessuto (non sfoderabile).

Bench. Steel frame, chrome-plated or painted. Seat made of polyurethane foam. Leather or fabric covers (not removable).

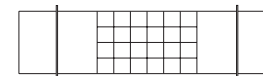
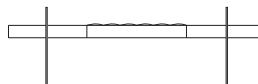

art. 5100  
L/W 219 P/D 59 H 41  
W 86.2" D 23.2" H 16.1"

## ONDA

design Fabio Bortolani

POUFF OTTOMAN

Pagina\_Page 147

Pouff. Struttura in legno ricoperta in poliuretano e dacron. Rivestimento in pelle o tessuto completamente sfoderabile. Gambe in acciaio verniciato o cromato.

Ottoman. Wooden frame covered with polyurethane foam and dacron. Removable leather or fabric covers. Painted or chrome-plated steel feet.

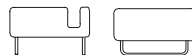

ONDA 1 art. 6001  
L/W 65 P/D 65 H 42  
W 25.6" D 25.6" H 16.5"

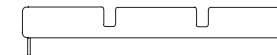

ONDA 3 art. 6003  
L/W 215 P/D 65 H 42  
W 84.6" D 25.6" H 16.5"

Cuscino / bracciolo. Cushion / armrest.



ONDA 2 art. 6002  
L/W 140 P/D 65 H 42  
W 55.1" D 25.6" H 16.5"



ONDA art. 6001C  
L/W 65 P/D 10 H 31  
W 25.6" D 3.9" H 12.2"

## SNAKE

design Matteo Scandola

PANCA

BENCH

Pagina\_Page 149

Panca. Gambe in acciaio cromato o verniciato. Seduta imbottita in gomma poliuretanic. Rivestimento in pelle o tessuto sfoderabile.

Bench. Steel legs, chrome-plated or painted. Seat made of polyurethane foam. Removable leather or fabric covers.

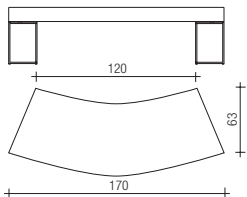

art. 5102  
L/W 170 P/D 63 H 44  
W 66.9" D 24.8" H 17.3"

Tavolino di collegamento in alluminio laccato. / Connecting table in painted aluminium.

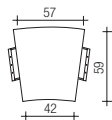

art. 5103  
L/W 57 P/D 42  
W 22.4" D 16.5"

## CARTESIANO

design Claudio Bitetti

PANCA

BENCH

Pagina\_Page 151

Struttura in acciaio ricoperta in gomma poliuretanic. Rivestimento in tessuto sfoderabile.

Steel frame covered in polyurethane foam. Removable fabric cover.

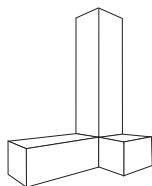

art. 9300  
L/W 150 P/D 90 H 231  
altezza seduta cm. 45  
W 59" D 35.4" H 90.9"  
seat height 17.7"

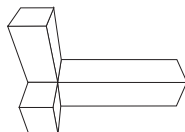

L/W 231 P/D 90 H 150  
W 90.9" D 35.4" H 59"

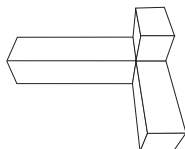

L/W 231 P/D 150 H 90  
W 90.9" D 59" H 35.4"

## ALTEA

design Giuseppe Bavuso

CREDENZA

SIDEBOARD

Pagina\_Page 153

Credenza a due ante in lamellare di ebano o in MDF laccato lucido. Vetrinetta in cristallo temperato fumé spessore 6 mm. rivestita in cuoio. Luce interna. Due cassetti ed un ripiano interni. Nella versione laccata, l'interno dei cassetti è rivestito in un materiale innovativo e tecnologico intramato come un tessuto, elegantissimo e leggero ma molto resistente.

Sideboard in ebony or in glossy lacquered MDF. Two doors. Tempered glass cabinet, smoke-grey 6 mm. thick with hide. Inside light. Two inner drawers and one shelf. In the lacquered version, inner drawers are lined in an innovative and technological material woven like cloth, elegant and lightweight, but highly resistant.

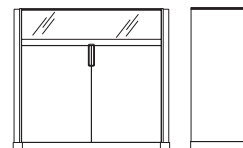

art. CA 1  
L/W 126 H 114 P/D 49,5  
W 49.6" H 44.9" D 19.5"

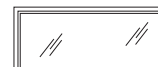

375

## EDOMADIA

design Giuseppe Bavuso

CREDENZA

SIDEBOARD

Pagina\_Page 161

Credenza in legno laccato. Base in acciaio cromato o verniciato. Vassoio porta bottiglie in alluminio

Sideboard in lacquered wood. Chrome-plated, or painted steel base. Aluminium bottle rack.

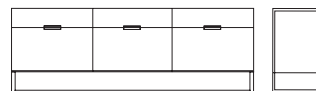

art. CE1  
L/W 220 H 76 P/D 50  
W 86.6" H 29.9" D 19.7"



## KUBIT

design Giuseppe Bavuso

MADIA      SIDEBOARD

Pagina\_Page    167

Madia in legno laccato o in rovere con quattro cassetti. Piano in marmo "bianco Michelangelo", "nero Marquinia" o in "pietra Serena". Base in alluminio spazzolato anodizzato finitura seta. Vassoio portabottiglie in alluminio.

Sideboard in oak or in lacquered wood with four drawers. Top in "white Michelangelo" or "black Marquinia" marble or in "Serena stone". "Silk finish" brushed and anodised aluminium base. Aluminium bottle rack.

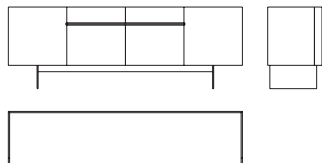

art. CK1  
L/W 220 H 77    P/D 51  
W 86.6" H 30.3" D 20"

## PORTLAND

design Giuseppe Bavuso

MADIA      SIDEBOARD

Pagina\_Page    173

Madia in legno laccato lucido o in rovere con ante scorrevoli e quattro cassettoni. Piani in marmo "bianco Michelangelo", "nero Marquinia" o in "pietra Serena".

Sideboard in oak or in glossy lacquered wood with sliding doors and four little drawers. Tops in "white Michelangelo" or "black Marquinia" marble or in "Serena stone".

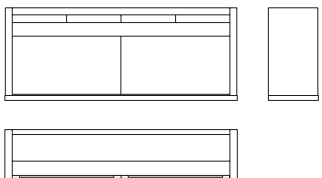

art. CP1  
L/W 235 H 94    P/D 51  
W 92.5" H 37" D 20"

## DENVER/V

design Giuseppe Bavuso

MADIA      SIDEBOARD

Pagina\_Page    181

Madia alta in rovere o in MDF laccato lucido con due ante scorrevoli. Anta a ribalta in cristallo con luce interna. Piani in marmo "bianco Michelangelo" o in "Pietra Serena".

Sideboard in oak or in glossy lacquered MDF with two sliding doors. Folding door in glass with inside light. Tops in "white Michelangelo" marble or in "Serena stone".



art. CDV1  
L/W 180 H 175    P/D 50  
W 70.9" H 68.9" D 19.7"

# 377

## CUBIC

design Enrico Cesana

MADIA      SIDEBOARD

Pagina\_Page    187

Madia in MDF laccato lucido o opaco con due cassettoni esterni e due cassettoni interni.

Sideboard in glossy or matt lacquered MDF with two external drawers and two inner drawers.



art. CC1  
L/W 200 H 64    P/D 55  
W 78.7" H 25.2" D 21.6"

## SLIDE

design Enrico Cesana

MADIA      SIDEBOARD

Pagina\_Page    191

Madia in MDF laccato lucido o opaco con vano a giorno illuminato con LED ed un cassettone. Due cassettoni.

Sideboard in glossy or matt lacquered MDF with open, LED illuminated compartment and large drawer. Two drawers.

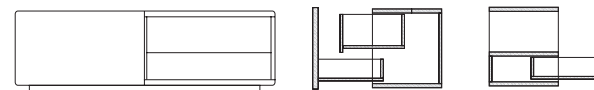

art. CS1  
L/W 238.5 H 64    P/D 55  
W 93.9" H 25.2" D 21.6"

## CONTAINER

design Bruno Rainaldi

CONTENITORE CABINET

Pagina\_Page 197

Base in acciaio e contenitore in MDF, entrambi laccati in laminato liquido o laccato lucido. Ripiani in legno.

Steel frame + cabinet in MDF, both painted with a liquid laminate finish or glossy lacquered. Wooden shelves.

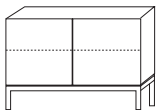

art. 9095  
L/W 130 P/D 42 H 85  
W 51.2" D 16.5" H 33.5"

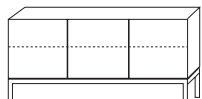

art. 9096  
L/W 195 P/D 42 H 85  
W 76.8" D 16.5" H 33.5"

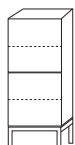

art. 9097  
L/W 65 P/D 42 H 150  
W 25.6" D 16.5" H 59"

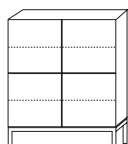

art. 9098  
L/W 130 H 150 P/D 42  
W 51.2" H 59" D 16.5"

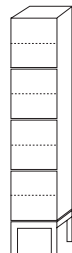

art. 8064A  
L/W 42 H 188 P/D 42  
W 16.5" H 74" D 16.5"

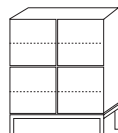

art. 8074A  
L/W 84 H 104 P/D 42  
W 33" H 40.9" D 16.5"

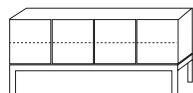

art. 8094A  
L/W 168 H 62 P/D 42  
W 66.1" H 24.4" D 16.5"

## RADAR

design Giuseppe Bavuso

TAVOLO TABLE

Pagina\_Page 205



Tavolo. Base in ghisa verniciata nera o bianca. Gamba in acciaio tagliato al laser cromata o verniciata bianca. Piano in marmo, pietra acrilica bianca S28 Alpine white  L6 HI-MACS o MDF laccato laminato liquido.

Table. Basement in white or black-painted cast iron. Laser-cut steel bars chrome-plated or white painted. Top in marble, S28 Alpine white acrylic stone  L6 HI-MACS or in MDF painted in liquid laminate.



art. TR120  
Ø 120 H 73  
Ø 47.2" H 28.7"

art. TR137  
Ø 137 H 73  
Ø 53.9" H 28.7"

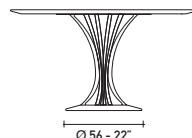
art. TR150  
Ø 150 H 73  
Ø 59" H 28.7"

## LOTO

design Giuseppe Bavuso

TAVOLO RETTANGOLARE

RECTANGULAR TABLE

Pagina\_Page 209

Tavolo rettangolare allungabile. Base in acciaio inox lucidato a specchio. Piano rettangolare allungabile disponibile in lamellare di ebano o in MDF laccato.

Extendable rectangular table. Stainless steel base, polished to a mirror finish. Extendable top available in ebony or in lacquered MDF.



art. TL 210 A  
L/W 210/268 H 74 P/D 95  
W 82.7"/105.5" H 29.1" D 37.4"

TAVOLO OVALE

OVAL TABLE

Pagina\_Page 213

Tavolo ovale. Base in acciaio inox lucidato a specchio. Piano ovale disponibile in: granito nero assoluto, marmo Calacatta oro, marmo bianco Michelangelo, marmo cristallizzato, MDF laccato, pietra acrilica bianca S28 Alpine White  L6 HI-MACS.

Oval table. Stainless steel base, polished to a mirror finish. Oval top available in: absolute black granite, gold Calacatta marble, white Michelangelo marble, crystallized marble, lacquered MDF, S28 Alpine White acrylic stone  L6 HI-MACS.

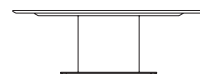

art. TL 220 O  
L/W 220 H 72 P/D 115  
W 86.6" H 28.3" D 45.3"

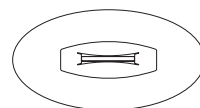

## PIGRECO

design Giuseppe Bavuso

TAVOLO TABLE Pagina\_Page 177

Tavolo. Struttura in rovere. Piano in marmo "bianco Michelangelo" (bordo interno mm. 20, bordo esterno mm. 15) o in "pietra Serena".

Table. Frame in oak. Top in "white Michelangelo" marble (thickness inside mm. 20 outside mm. 15) or in "Serena stone".



art. T2  
L/W 240 H 74 P/D 90  
W 94.5" H 29.1" D 35.4"

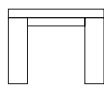

## XT

design Giuseppe Bavuso

TAVOLO TABLE Pagina\_Page 215

Tavolo. Struttura in acciaio inox spazzolato. Piano in rovere o laccato lucido.

Table. Brushed stainless steel legs. Top in oak or in glossy lacquered wood.



art. T3  
L/W 190 H 73.5 P/D 90  
W 74.8" H 28.9" D 35.4"

art. T3A  
L/W 220 H 73.5 P/D 90  
W 86.6" H 28.9" D 35.4"

art. T3B  
L/W 240 H 73.5 P/D 90  
W 94.5" H 28.9" D 35.4"

art. T3C  
L/W 280 H 73.5 P/D 90  
W 110.2" H 28.9" D 35.4"

## BIG TABLE

design Roberto Lazzeroni

TAVOLO TABLE Pagina\_Page 219

Tavolo. Gambe in piatto d'acciaio cromato o verniciato. Piano in legno spessore 5 cm. laccato lucido, rovere o laccato laminato liquido.

Table. Legs made of flat steel, chrome-plated or painted. Wooden top thickness cm. 5 available as follows: glossy lacquered, liquid laminate paint, oak.

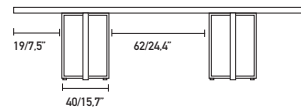

art. 7019 A  
L/W 180 H 72 P/D 90  
W 70.9" H 28.3" D 35.4"

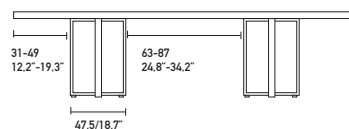

art. 7019  
L/W 220 H 72 P/D 90  
W 86.6" H 28.3" D 35.4"

art. 7029  
L/W 280 H 72 P/D 90  
W 110.2" H 28.3" D 35.4"

## VERNISSAGE

design Bruno Rainaldi

TAVOLO TABLE Pagina\_Page 223

Tavolo. Base in tubo di acciaio verniciato. Piano in legno laccato opaco o laccato laminato liquido. Spessore 6 cm.

Table. Base made of painted steel tube. Wooden top, matt lacquered or painted with a liquid laminate finish. Thickness cm. 6.

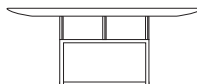

art. 9009B  
L/W 150 H 73 P/D 150  
W 59" H 28.7" D 59"

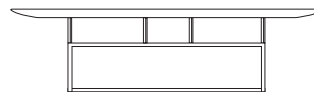

art. 9009A  
L/W 220 H 73 P/D 100  
L/W 86.6" H 28.7" D 39.4"

art. 9009D  
L/W 240 H 73 P/D 120  
L/W 94.5" H 28.7" D 47.2"

art. 9009C  
L/W 280 H 73 P/D 120  
L/W 110.2" H 28.7" D 47.2"



## CUT

design Alessandro Andreucci e Christian Hoist

TAVOLO TABLE Pagina\_Page 229

Tavolo. Base in acciaio cromato o laccato. Piano in cristallo, marmo o MDF laccato.

Table. Chrome-plated or painted steel basement. Top in glass, marble or painted MDF.



art. TC 120  
ø 120 / 137 H 73.5  
ø 47.2" / 53.9" H 28.7"



art. TC 225  
L/W 225 H 73.5 P/D 100  
W 88.6" H 28.7" D 39.4"

art. TC 240  
L/W 240 H 73.5 P/D 100  
W 94.5" H 28.7" D 39.4"

art. TC 280  
L/W 280 H 73.5 P/D 100  
W 119.2" H 28.7" D 39.4"

## BIPLANO

design Pietro Arosio

TAVOLO TABLE Pagina\_Page 241

Tavolo ovale. Struttura in metallo verniciato. Piano superiore in cristallo spessore 15 mm. Piano inferiore in rovere o laccato lucido.

Oval table. Metal frame, painted. Upper top in glass 15 mm. Lower top in oak or glossy laquered.

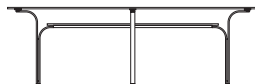

art. 4019  
L/W 240 H 74 P/D 140  
W 94.5" H 29.1" D 55.1"

art. 4019A  
L/W 280 H 74 P/D 140  
W 110.2" H 29.1" D 55.1"

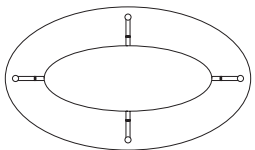

## AXIA

design Giuseppe Bavuso

SEDIA CHAIR Pagina\_Page 245

Sedia. Struttura in tubo di acciaio cromato o laccato. Rivestimento in cuoio.

Chair. Frame in chrome-plated or painted tubular steel. Seat and back in hide.



art. D6  
L/W 43 H 77 P/D 48  
W 16.9" H 30.3" D 18.9"

## WING CHAIR

design Giuseppe Bavuso

SEDIA CHAIR Pagina\_Page 249

art. SW1

Sedia. Seduta e spalliera in poliuretano stampato e rivestito in pelle o cavallino. Struttura in pressofusione di alluminio con finiture: alluminio lucido o verniciato.

art. SW1

Chair. Seat and back made of moulded polyurethane foam covered in leather or cow skin. Pressure die-casting aluminium frame with choice of finishes: polished or painted aluminium.

art. SW2

Sedia. Seduta e spalliera in corda intrecciata colore naturale, nera o bianca. Struttura in pressofusione di alluminio con finiture: alluminio lucido o verniciato.

art. SW2

Chair. Seat and back made of woven cord in natural, black or white colour. Pressure die-casting aluminium frame with choice of finishes: polished or painted aluminium.



art. SW1  
L/W 50 H 75 P/D 55  
W 19.7" H 29.5" D 21.6"



art. SW2  
L/W 50 H 75 P/D 55  
W 19.7" H 29.5" D 21.6"

## TANGO

design Archirivolto

SEDIA CHAIR Pagina\_Page 251

Sedia impilabile. Base in pressofusione di alluminio lucidato o verniciato. Scocca in nylon lucido coiniettato. Profilo superiore in pressofusione di alluminio.

Stacking chair. Frame in pressure die-casting aluminium, polished or painted. Shell in glossy injected nylon. Profile in pressure die-casting aluminium.



art. ST1  
L/W 47 H 80 P/D 50  
W 18.5" H 31.5" D 19.7"

## JAZZ

design Archirivolto

SEDIA CHAIR Pagina\_Page 253

Sedia impilabile. Base in pressofusione di alluminio lucidato o verniciato. Scocca in nylon lucido coiniettato.

Stacking chair. Frame in pressure die-casting aluminium, polished or painted. Shell in glossy injected nylon.

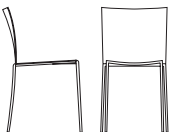

art. SJ1  
L/W 47 H 80 P/D 53  
W 18.5" H 31.5" D 20.9"

## LOLLIPOP

design Archirivolto

SEDIA CHAIR Pagina\_Page 255

Sedia impilabile con struttura in tubo estruso di alluminio anodizzato lucido o verniciato. La scocca, realizzata in materiale plastico Polimero "San" con l'esclusiva tecnica di bi-iniezione, può essere trasparente o coprente con finitura lucida.

Stackable chair with frame made of extruded anodized aluminium, polished or painted. The shell is made of Polymer "San" plastic using an exclusive bi-injection technique, and may either be transparent or matt with glossy finish.



art. SL1  
L/W 48 H 83 P/D 49  
W 18.9" H 32.7" D 19.3"



Particolare della struttura  
Detail of the frame

Sedia impilabile come sopra con struttura in tubo di acciaio cromato o verniciato.

Stackable chair as above with frame made of chrome-plated or painted steel tube.



art. SL2  
L/W 48 H 83 P/D 49  
W 18.9" H 32.7" D 19.3"

Sedia impilabile come sopra con struttura in tondino di acciaio cromato o verniciato.

Stackable chair as above with frame made of chrome-plated or painted steel wire.



art. SL3  
L/W 48 H 83 P/D 49  
W 18.9" H 32.7" D 19.3"

## SIMPLE CHAIR

design Roberto Lazzeroni

SEDIA CHAIR Pagina\_Page 261

Sedia. Gambe in piatto di acciaio cromato o verniciato. Scocca in legno rivestita in gomma poliuretana. Rivestimento in pelle e tessuto.

Chair. Chrome-plated or painted flat steel legs. Wooden shell covered with polyurethane foam. Leather or fabric covers.

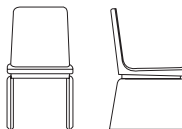

art. 7014  
L/W 44.5 H 86.5 P/D 57  
W 17.5" H 34" D 22.4"

## ICE S

design Alessandro Andreucci e Christian Hoist

SEDIA CHAIR Pagina\_Page 265

Sedia. Gambe in acciaio cromato o verniciato. Scocca in legno rivestita in gomma poliuretana. Rivestimento in cuoio.

Chair. Chrome-plated or painted steel legs. Wooden shell covered with polyurethane foam. Hide covering.



art. ICE S  
L/W 50 H 77 P/D 60  
W 19.7" H 30.3" D 23.6"

## KIRON

design Archirivolto

SGABELLO STOOL Pagina\_Page 267

Sgabello con seduta in policarbonato nei colori: trasparente, arancio, verde acido, rosso rubino, bianco lucido e nero lucido. La sua struttura in acciaio cromato con meccanismo a gas permette una regolazione in altezza ed una rotazione totale.

Stool. Seat made of polycarbonate available in the following colours: clear, orange, acid green, ruby, glossy white, glossy black. Its chrome-plated steel frame, featuring a gas mechanism, permits height adjustment and total rotation.

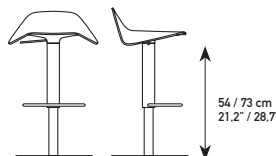



art. SK1  
L/W 44 H 85 max P/D 44  
W 17.3" H 33.5" D 17.3"

## HARPA

design Giuseppe Bavuso

TAVOLINO SIDE AND COFFEE TABLE Pagina\_Page 271

Tavolino. Base in acciaio cromato o laccato. Piano disponibile in: pietra acrilica bianca S28 Alpine White  LG HI-MACS, marmo Marquinia nero, marmo bianco Michelangelo, marmo cristallizzato, lamellare di ebano o laccato lucido.

Coffee table. Chrome-plated or painted steel base. Top available in: S28 Alpine white acrylic stone  LG HI-MACS, black Marquinia marble, white Michelangelo marble, crystallized marble, ebony or glossy lacquered.

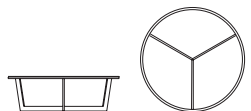

art. TH 72  
Ø 72 H 24  
Ø 28.3" H 9.5"



art. TH 43  
Ø 43 H 48  
Ø 16.9" H 19.9"



art. TH 95  
Ø 95 H 31,5  
Ø 37.4" H 12.4"

## UP

design Giuseppe Bavuso

TAVOLINO SIDE AND COFFEE TABLE Pagina\_Page 277

Tavolino. Struttura in tubo di acciaio cromato o laccato. Piano in rovere, laccato lucido o in marmo "bianco Michelangelo" o "nero Marquinia".

Coffee table. Frame in chrome-plated or painted tubular steel. Top in oak, in glossy lacquered wood or in "white Michelangelo" or "black Marquinia" marble.



UP1 art. T8  
L/W 50 H 22 P/D 88.3  
W 19.7" H 8.7" D 34.8"



UP2 art. T9  
L/W 90 H 22 P/D 88.3  
W 35.4" H 8.7" D 34.8"

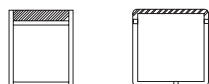

UP3 art. T10  
L/W 40 H 50 P/D 42  
W 15.7" H 19.7" D 16.5"

## DAYTONA

design Giuseppe Bavuso

TAVOLINO COFFEE TABLE Pagina\_Page 279

Tavolino. Base in acciaio cromato o laccato. Piano in rovere o laccato lucido.

Coffee table. Chrome-plated or painted steel frame. Top in oak or glossy lacquered.



art. T11A25  
L/W 70 H 25 P/D 70  
W 27.6" H 9.8" D 27.6"

art. T11A15  
L/W 70 H 15 P/D 70  
W 27.6" H 5.9" D 27.6"



art. T11B25  
L/W 90 H 25 P/D 90  
W 35.4" H 9.8" D 35.4"

art. T11B15  
L/W 90 H 15 P/D 90  
W 35.4" H 5.9" D 35.4"

## CLUB

design Giuseppe Bavuso

TAVOLINO SIDE AND COFFEE TABLE Pagina\_Page 281

Tavolino. Base in acciaio cromato. Piano in rovere, laccato lucido o marmo bianco Michelangelo o nero Marquinia.

Coffee table. Chrome-plated steel frame. Top in oak, glossy lacquered or in white "Michelangelo" or black "Marquinia" marble.



art. T12  
L/W 48 H 23 P/D 78.5  
W 19.9" H 9.1" D 30.9"



art. T14  
L/W 39 H 50 P/D 39  
W 15.3" H 19.7" D 15.3"



art. T13  
L/W 76 H 23 P/D 76  
W 29.9" H 9.1" D 29.9"

## BENCH

design Giuseppe Bavuso

TAVOLINO COFFEE TABLE Pagina\_Page 283

Tavolino in rovere o laccato lucido con due cassetti interni laterali.

Coffee table in oak or glossy lacquered wood with 2 side drawers.

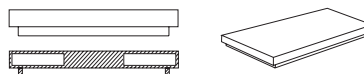

art. T6  
L/W 126 H 19 P/D 86  
W 49.6" H 7.5" D 33.8"

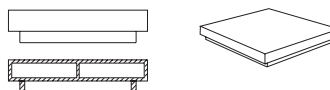

art. T7  
L/W 86 H 19 P/D 86  
W 33.8" H 7.5" D 33.8"

## BLADE/B

design Giuseppe Bavuso

LETTO	BED	Pagina_Page	285
-------	-----	-------------	-----

Letto. Gambe e cornice testata in acciaio cromato o laccato. Testata e giroletto imbottiti in gomma poliuretana e Dacron. Rivestimento in pelle o tessuto. Rete con doghe di faggio.

Bed. Legs and the headboard frame in chrome-plated or painted steel. Headboard and sides covered with polyurethane foam and Dacron. Leather or fabric covers. Bed slats in beech wood.

art. LBB1 Letto. Bed.

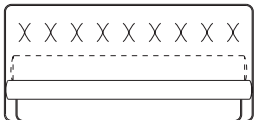

art. LBB1S per materasso / for mattress  
Standard L/W 172 H 84 P/D 215 L/W 160 P/D 197  
L/W 67.7" H 33" D 84.6" L/W 63" D 77.5"

art. LBB1Q  
Queen Size L/W 162 H 84 P/D 221 L/W 150 P/D 203  
L/W 63.8" H 33" D 87" L/W 59" D 79.9"

art. LBB1K  
King Size L/W 205 H 84 P/D 221 L/W 193 P/D 203  
L/W 80.7" H 33" D 87" L/W 76" D 79.9"

art. LBB1E  
Europe L/W 192 H 84 P/D 218 L/W 180 P/D 200  
L/W 75.6" H 33" D 85.8" L/W 70.9" D 78.7"

## BLADE/A

design Giuseppe Bavuso

LETTO	BED	Pagina_Page	291
-------	-----	-------------	-----

Letto. Gambe e cornice testata in acciaio cromato o laccato. Testata e giroletto imbottiti in gomma poliuretana e Dacron. Rivestimento in pelle o tessuto. Rete con doghe di faggio.

Bed. Legs and the headboard frame in chrome-plated or painted steel. Headboard and sides covered with polyurethane foam and Dacron. Leather or fabric covers. Bed slats in beech wood.

art. LBB2 Letto. Bed.

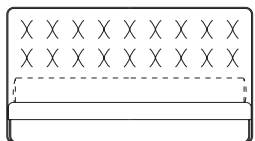

art. LBB2S per materasso / for mattress  
Standard L/W 172 H 95 P/D 215 L/W 160 P/D 197  
L/W 67.7" H 37.4" D 84.6" L/W 63" D 77.5"

art. LBB2Q  
Queen Size L/W 162 H 95 P/D 221 L/W 150 P/D 203  
L/W 63.8" H 37.4" D 87" L/W 59" D 79.9"

art. LBB2K  
King Size L/W 205 H 95 P/D 221 L/W 193 P/D 203  
L/W 80.7" H 37.4" D 87" L/W 76" D 79.9"

art. LBB2E  
Europe L/W 192 H 95 P/D 218 L/W 180 P/D 200  
L/W 75.6" H 37.4" D 85.8" L/W 70.9" D 78.7"

## ECHO

design Giuseppe Bavuso

LETTO	BED	Pagina_Page	293
-------	-----	-------------	-----

Letto. Testata in legno rivestita in poliuretano e piuma d'oca. Base in legno rivestita in poliuretano. Rivestimento in pelle o tessuto. Cornice e gambe in acciaio cromato. Rete con doghe in faggio.

Bed. Headboard made of wood upholstered with polyurethane foam and down. Wooden edge upholstered with polyurethane foam. Leather or fabric covers. Edge and legs made of chrome-plated steel. Beechwood slats.

art. LS1 Letto con base con cornice.  
Bed. Base with edge.

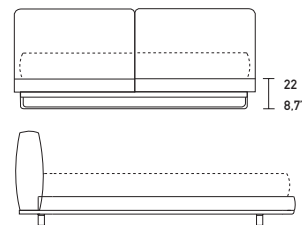

art. LS1S / art. LS2S per materasso / for mattress  
Standard L/W 182 H 75 P/D 226 L/W 170 P/D 197  
L/W 71.6" H 29.5" D 89" L/W 66.9" D 77.5"

art. LS1Q / art. LS2Q  
Queen Size L/W 172 H 75 P/D 232 L/W 150 P/D 203  
L/W 67.7" H 29.5" D 91.3" L/W 59" D 79.9"

art. LS2 Letto con base senza cornice.  
Bed. Base with no edge.

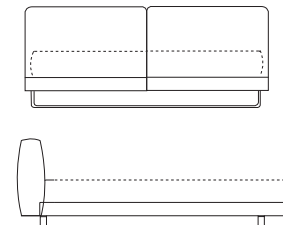

art. LS1K / art. LS2K per materasso / for mattress  
King Size L/W 204 H 75 P/D 232 L/W 193 P/D 203  
L/W 80.3" H 29.5" D 91.3" L/W 76" D 79.9"

art. LS1E / art. LS2E  
Europe L/W 192 H 75 P/D 229 L/W 180 P/D 200  
L/W 75.6" H 29.5" D 90.1" L/W 70.9" D 78.7"

## FENG

design Giuseppe Bavuso

LETTO	BED	Pagina_Page	299
-------	-----	-------------	-----

Letto. Struttura in acciaio imbottita in gomma poliuretana e dacron. Rivestimento in pelle o tessuto. Basamento in alluminio spazzolato anodizzato finitura seta. Rete con doghe di faggio.

Bed. Steel frame upholstered with polyurethane foam and dacron. Leather or fabric covers. "Silk finish" brushed anodised aluminium basement. Beechwood slats.

art. LF1 Letto. Bed.

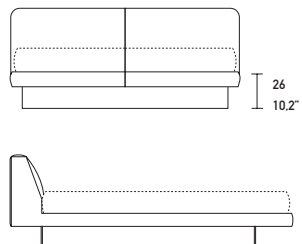

art. LF1S per materasso / for mattress  
Standard L/W 170 H 73 P/D 222 L/W 160 P/D 197  
L/W 66.9" H 28.7" D 87.4" L/W 63" D 77.5"

art. LF1Q  
Queen Size L/W 160 H 73 P/D 228 L/W 150 P/D 203  
L/W 63" H 28.7" D 89.8" L/W 59" D 79.9"

art. LF1K  
King Size L/W 203 H 73 P/D 228 L/W 193 P/D 203  
L/W 79.9" H 28.7" D 89.8" L/W 76" D 79.9"

art. LF1E  
Europe L/W 190 H 73 P/D 225 L/W 180 P/D 200  
L/W 74.8" H 28.7" D 88.6" L/W 70.9" D 78.7"

## KENDO

design Giuseppe Bavuso

LETTO BED Pagina\_Page 303

Letto. Struttura in acciaio imbottita in gomma poliuretana e dacron. Rivestimento in pelle o tessuto. Base in acciaio cromato o verniciato. Rete con doghe di faggio.

Bed. Steel frame upholstered with polyurethane foam and dacron. Leather or fabric covers. Steel basement, chrome-plated or painted. Beechwood slats.

art. LK1 Letto. Bed.

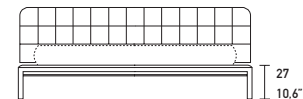

art. LK1S Standard	L/W 190 L/W 74.8"	H 75 H 29.5"	P/D 224 D 88.2"	per materasso / for mattress L/W 160 P/D 197 L/W 63" D 77.5"
-----------------------	----------------------	-----------------	--------------------	--

art. LK1Q Queen Size	L/W 180 L/W 70.9"	H 75 H 29.5"	P/D 230 D 90.5"	L/W 150 P/D 203 L/W 59" D 79.9"
-------------------------	----------------------	-----------------	--------------------	------------------------------------

art. LK1K King Size	L/W 223 L/W 87.8"	H 75 H 29.5"	P/D 230 D 90.5"	L/W 193 P/D 203 L/W 76" D 79.9"
------------------------	----------------------	-----------------	--------------------	------------------------------------

art. LK1E Europe	L/W 210 L/W 82.7"	H 75 H 29.5"	P/D 227 D 89.4"	L/W 180 P/D 200 L/W 70.9" D 78.7"
---------------------	----------------------	-----------------	--------------------	--------------------------------------

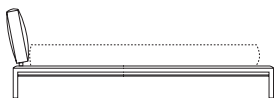

## PLAZA

design Giuseppe Bavuso

LETTO BED Pagina\_Page 307

Letto. Base e comodini in legno. Testata imbottita. Rivestimento in pelle o tessuto. Rete con doghe di faggio.

Bed. Basement and side tables in wood. Upholstered headboard. Leather or fabric covers. Beechwood slats.

art. LP1  
Letto. Bed.

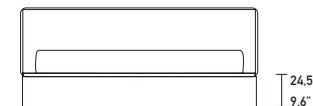

art. LP1S Standard	L/W 182 L/W 71.6"	H 76.5 H 30.1"	P/D 217 D 85.4"	per materasso / for mattress L/W 160 P/D 197 L/W 63" D 77.5"
-----------------------	----------------------	-------------------	--------------------	--

art. LP1Q Queen Size	L/W 172 L/W 67.7"	H 76.5 H 30.1"	P/D 223 D 87.8"	L/W 150 P/D 203 L/W 59" D 79.9"
-------------------------	----------------------	-------------------	--------------------	------------------------------------

art. LP1K King Size	L/W 215 L/W 84.6"	H 76.5 H 30.1"	P/D 223 D 87.8"	L/W 193 P/D 203 L/W 76" D 79.9"
------------------------	----------------------	-------------------	--------------------	------------------------------------

art. LP1E Europe	L/W 202 L/W 79.5"	H 76.5 H 30.1"	P/D 220 D 86.6"	L/W 180 P/D 200 L/W 70.9" D 78.7"
---------------------	----------------------	-------------------	--------------------	--------------------------------------

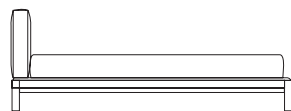

art. LP1C

Letto con comodini. Bed with side tables.

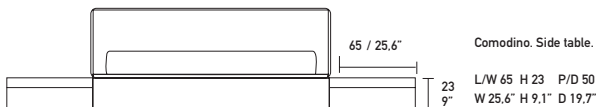

Comodino. Side table.

L/W 65 H 23 P/D 50 W 25.6" H 9.1" D 19.7"
--

## BED BOSS

LETTO BED Pagina\_Page 311

Letto con testata capitonné. Struttura in acciaio rivestita in espanso. Base in tubo di acciaio verniciato o cromato. Rete con doghe in faggio. Disponibile in varie misure.

Bed with quilted headrest. Steel frame covered with polyurethane foam. Base in steel tube, painted or chrome-plated. Beechwood slats. Available in different sizes.

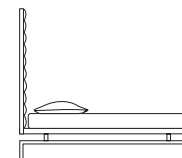
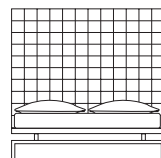

Boss bed HIGH  
Art. 9007

art. 9007S - Standard	L/W 175 W 68.9"	H 169 H 66.5"	P/D 209 D 82.3"	per materasso for mattress	L/W 170 W 66.9"	P/D 197 D 77.5"
-----------------------	--------------------	------------------	--------------------	-------------------------------	--------------------	--------------------

art. 9007Q - Queen-Size	L/W 161 W 63.4"	H 169 H 66.5"	P/D 215 D 84.6"	per materasso for mattress	L/W 150 W 59"	P/D 203 D 79.9"
-------------------------	--------------------	------------------	--------------------	-------------------------------	------------------	--------------------

art. 9007K - King-Size	L/W 205 W 80.7"	H 169 H 66.5"	P/D 215 D 84.6"	per materasso for mattress	L/W 193 W 76"	P/D 203 D 79.9"
------------------------	--------------------	------------------	--------------------	-------------------------------	------------------	--------------------

art. 9007E - Europe	L/W 190 W 74.8"	H 169 H 66.5"	P/D 212 D 83.5"	per materasso for mattress	L/W 180 W 70.9"	P/D 200 D 78.7"
---------------------	--------------------	------------------	--------------------	-------------------------------	--------------------	--------------------

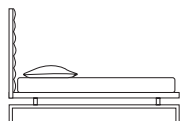
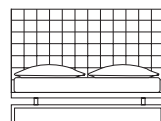

Boss bed MEDIUM  
Art. 9087

art. 9087S - Standard	L/W 175 W 68.9"	H 124 H 48.8"	P/D 209 D 82.3"	per materasso for mattress	L/W 170 W 66.9"	P/D 197 D 77.5"
-----------------------	--------------------	------------------	--------------------	-------------------------------	--------------------	--------------------

art. 9087Q - Queen-Size	L/W 161 W 63.4"	H 124 H 48.8"	P/D 215 D 84.6"	per materasso for mattress	L/W 150 W 59"	P/D 203 D 79.9"
-------------------------	--------------------	------------------	--------------------	-------------------------------	------------------	--------------------

art. 9087K - King-Size	L/W 205 W 80.7"	H 124 H 48.8"	P/D 215 D 84.6"	per materasso for mattress	L/W 193 W 76"	P/D 203 D 79.9"
------------------------	--------------------	------------------	--------------------	-------------------------------	------------------	--------------------

art. 9087E - Europe	L/W 190 W 74.8"	H 124 H 48.8"	P/D 212 D 83.5"	per materasso for mattress	L/W 180 W 70.9"	P/D 200 D 78.7"
---------------------	--------------------	------------------	--------------------	-------------------------------	--------------------	--------------------

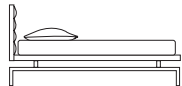
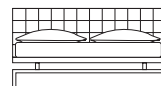

Boss bed LOW  
Art. 9017

art. 9017S - Standard	L/W 175 W 68.9"	H 94 H 37"	P/D 209 D 82.3"	per materasso for mattress	L/W 170 W 66.9"	P/D 197 D 77.5"
-----------------------	--------------------	---------------	--------------------	-------------------------------	--------------------	--------------------

art. 9017Q - Queen-Size	L/W 161 W 63.4"	H 94 H 37"	P/D 215 D 84.6"	per materasso for mattress	L/W 150 W 59"	P/D 203 D 79.9"
-------------------------	--------------------	---------------	--------------------	-------------------------------	------------------	--------------------

art. 9017K - King-Size	L/W 205 W 80.7"	H 94 H 37"	P/D 215 D 84.6"	per materasso for mattress	L/W 193 W 76"	P/D 203 D 79.9"
------------------------	--------------------	---------------	--------------------	-------------------------------	------------------	--------------------

art. 9017E - Europe	L/W 190 W 74.8"	H 94 H 37"	P/D 212 D 83.5"	per materasso for mattress	L/W 180 W 70.9"	P/D 200 D 78.7"
---------------------	--------------------	---------------	--------------------	-------------------------------	--------------------	--------------------

art. SE 1  
Cassettone in legno laccato lucido, opaco o in rovere. Base in acciaio cromato o laccato. Chest of drawers in glossy laquered, matt laquered wood or in oak. Chrome-plated or painted steel base.

Cassettone. Chest of drawers.

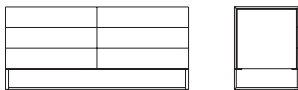

art. SE 1  
L/W 150 H 68 P/D 53  
W 59" H 26.8" D 20.9"

art. SE 2  
Settimanale in legno laccato lucido, opaco o in rovere. Base in acciaio cromato o laccato. High chest of drawers in glossy laquered, matt lacquered wood or in oak. Chrome-plated or painted steel base.

Settimanale. High chest of drawers.

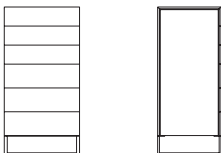

art. SE 2  
L/W 63 H 124 P/D 53  
W 24.8" H 48.8" D 20.9"

art. SE 3 - art. SE 3/B  
Comodino in legno laccato lucido, opaco o in rovere. Base in acciaio cromato o laccato. Bedside table in glossy laquered, matt lacquered wood or in oak. Chrome-plated or painted steel base.

Comodino. Bedside table.



art. SE 3  
L/W 63 H 32 P/D 48  
W 24.8" H 12.6" D 18.9"



art. SE 3/B  
L/W 63 H 45 P/D 48  
W 24.8" H 17.7" D 18.9"

art. SES 1  
Cassettone in MDF laccato lucido o opaco. Base in acciaio cromato o laccato. Chest of drawers in glossy or matt lacquered MDF. Chrome-plated or painted steel base.

Cassettone. Chest of drawers.

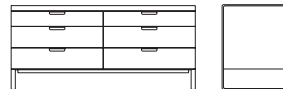

art. SES 1  
L/W 155 H 70 P/D 53  
W 61" H 27.5" D 20.9"

art. SES 2  
Settimanale in MDF laccato lucido o opaco. Base in acciaio cromato o laccato. High chest of drawers of drawers in glossy or matt lacquered MDF. Chrome-plated or painted steel base.

Settimanale. High chest of drawers.

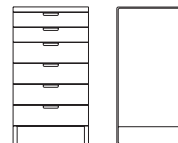

art. SES 2  
L/W 65 H 119 P/D 53  
W 25.6" H 46.8" D 20.9"

art. SES 3  
Comodino in MDF laccato lucido o opaco. Base in acciaio cromato o laccato. Bedside table in glossy or matt lacquered MDF. Chrome-plated or painted steel base.

Comodino. Bedside table.



art. SES 3  
L/W 65 H 34 P/D 48  
W 25.6" H 13.4" D 18.9"

art. SFJ1  
Cassettone. Fianchi in noce Canaletto, in lamellare di ebano o laccati lucidi bianco o nero. Top e cassetti rivestiti in cuoio.

Chest of drawers. Sides made of Canaletto walnut, in ebony or white or black glossy lacquered. Clad in hide on top and drawers.

Cassettone. Chest of drawers.



art. SFJ1  
L/W 158 H 66 P/D 55  
W 62.2" H 26" D 21.6"

art. SFJ2  
Settimanale. Fianchi in noce Canaletto, in lamellare di ebano o laccati lucidi bianco o nero. Top e cassetti rivestiti in cuoio.

High chest of drawers. Sides made of Canaletto walnut, in ebony or white or black glossy lacquered. Clad in hide on top and drawers.

Settimanale. High chest of drawers.



art. SFJ2  
L/W 67 H 125 P/D 55  
W 26.4" H 49.2" D 21.6"

art. SFJ3  
Comodino. Fianchi in noce Canaletto, in lamellare di ebano o laccati lucidi bianco o nero. Top e cassetti rivestiti in cuoio.

Bedside table. Sides made of Canaletto walnut, in ebony or white or black glossy lacquered. Clad in hide on top and drawers.

Comodino. Bedside table.



art. SFJ3  
L/W 67 H 33 P/D 50  
W 26.4" H 13" D 19.7"

art. SF1  
Cassettone in legno laccato lucido o in rovere. Fianchi in alluminio spazzolato anodizzato finitura seta.

art. SF1  
Chest of drawers in glossy lacquered wood or in oak. Sides in "Silk finish" brushed anodised aluminium.

Cassettone. Chest of drawers.

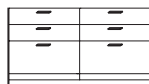

art. SF1  
L/W 144 H 66 P/D 51  
W 56.7" H 26" D 20"

art. SF2  
Settimanale in legno laccato lucido o in rovere. Fianchi in alluminio spazzolato anodizzato finitura seta.

art. SF2  
High chest of drawers in glossy lacquered wood or in oak. Sides in "Silk finish" brushed anodised aluminium.

Settimanale. High chest of drawers.



art. SF2  
L/W 64 H 124 P/D 51  
W 25.2" H 48.8" D 20"

art. SF3  
Comodino in legno laccato lucido o in rovere. Fianchi in alluminio spazzolato anodizzato finitura seta.

art. SF3  
Bedside table in glossy lacquered wood or in oak. Sides in "Silk finish" brushed anodised aluminium.

Comodino. Bedside table.



art. SF3  
L/W 68 H 28 P/D 48  
W 26.8" H 11" D 18.9"

## FRAME

design Giuseppe Bavuso

SPECCHIO MIRROR Pagina\_Page 337

Specchio. Profilo in alluminio spazzolato anodizzato finitura seta, con luce fluorescente interna.

Mirror: "Silk finish" brushed anodised aluminium frame. Inside fluorescent light.

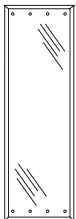

Art. L1  
L/W 46 H 150 P/D 5  
W 18.1" H 59" D 2"

Art. L3  
L/W 52 H 180 P/D 5  
W 20.5" H 70.9" D 2"

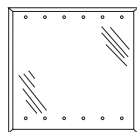

Art. L2  
L/W 86 H 86 P/D 5  
W 33.8" H 33.8" D 2"

## LOOK AT ME

design Bruno Rainaldi e Andrea Salvetti

SPECCHIO MIRROR Pagina\_Page 339

Specchiera singola a parete con cornice in fusione di alluminio decorata a mano.

Single mirror, frame in cast aluminium, hand-decorated.

Elemento singolo destro o sinistro.  
Left or right single element.

Elemento centrale.  
Central element.

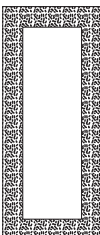

Art. 90B  
L/W 93 H 210  
W 36.6" H 82.7"



art. 90A DX - Art. 90A SX  
L/W 79.5 H 210  
W 31.3" H 82.7"



art. 90D  
L/W 66 H 210  
W 26" H 82.7"

Specchiera a parete composta da 3 elementi con cornice in fusione di alluminio stampata decorata a mano.

Wall-mirror composed by 3 elements. Frame in cast aluminium, hand-decorated.

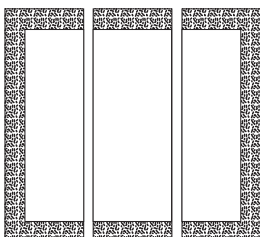

art. 90C  
L/W 230 H 210  
W 90.5" H 82.7"

## QUADRUS

design Bruno Rainaldi

SPECCHIO MIRROR Pagina\_Page 343

Specchio composto da pannello in legno laccato bianco con attacco a parete (sia verticale che orizzontale) e da quadri in lamiera laccati bianco distanziati di 1 cm.

Mirror consisting of a white wooden panel with wall attachment (vertical and horizontal) and squares in sheetmetal at 1 cm. distance, painted white.

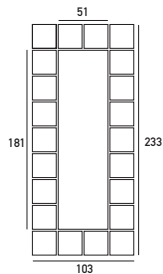

art. 91  
L/W 103 H 233 P/D 2.5  
W 40.5" H 91.7" D 1"

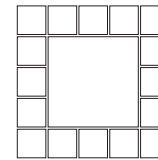

art. 92  
L/W 129 H 129 P/D 2.5  
W 50.8" H 50.8" D 1"

Elemento singolo destro o sinistro.  
Left or right single element.

Elemento centrale.  
Central element.

Specchiera a parete composta da 3 elementi.  
Wall-mirror composed by 3 elements.

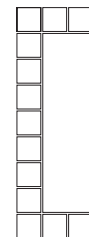

art. 94  
L/W 77 H 233 P/D 2.5  
W 30.3" H 91.7" D 1"



art. 95  
L/W 51 H 233 P/D 2.5  
W 20" H 91.7" D 1"

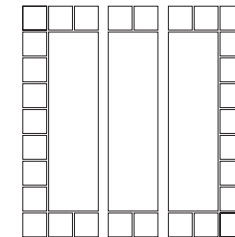

art. 96  
L/W 205 H 233 P/D 2.5  
W 80.7" H 91.7" D 1"

## AB NORMAL

design Bruno Rainaldi

OROLOGIO WALL-CLOCK Pagina\_Page 345

Orologio a parete in lamiera di acciaio verniciato bianco o alluminio con meccanismo a pila.

Wall-clock made of steel plate, painted white or aluminium. Battery mechanism.

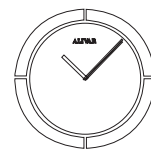

art. 9000  
Ø 140 P/D 6  
Ø 55.1" D 2.4"

397



EUROPA

---

ITALIA

Gianni Versace Milano  
Aeroporto di Bologna  
Navi Costa Crociere  
Aeroporto di Bolzano  
Pitti Firenze  
Cafè Renault Roma  
Fiera Bolzano  
Comune di Roma  
Banca d'Italia  
Credito Bergamasco  
Hotel Rafael Roma  
Officine Panerai  
Hotel Le Meridien Lingotto Torino  
Banca Antoniana  
A.C. Fiorentina  
Comune di Napoli  
Mada Hotels  
Relax Hotels  
Hotel Michelangelo  
(Chianciano Terme)  
Biblioteca Nazionale di Firenze  
Uffici della Provincia di Latina.  
La Farnesina, Roma  
Ministero dell'Interno, Roma  
American Express, Roma  
Eni Group, Milano  
Hotel Milano, Bergamo  
Una Hotels & Resort  
Cassa di Risparmio di Firenze  
Università LUISS, Roma  
Agriturismo S. Caterina, Assisi  
Harmont & Blaine Spa

OLANDA

SNC Bank  
Den Bosch Avero Verz. Mij  
Leeuwarden Groene Land Verz.  
Groningen  
De Amersfoortse Verz.  
Amersfoort Psych Centrum  
Zon & Schild  
Bilthoven KPMG Accountancy Nieuwegein  
Hotel La Bergère Maastricht

BELGIO

Villa Dirickz

GRECIA

Ioniki Bank of Greece  
Interamerican Group  
Nestle Headquarters Athens  
Piraens Bank Athens

REGNO UNITO

GRAN BRETAGNA  
Axon Solutions London  
ICAS Edinburgh  
The Park Restaurant London  
Goldman Sachs  
Revlon  
Leaf Bar Manchester  
The Willow Tea Room Glasgow  
The Kensington Hotel London  
London Mel B (Scary Spice) Spice Girls  
Spice Cube Restaurant

IRLANDA

Air Lingus

ISLANDA

Radisson sas  
1919 Hotel Reykjavik

REPUBBLICA CECA

Villa Tugendhat Brno  
Maximilian Hotel Prague

GERMANIA

Bosch Offices  
ABC Bank Berlin  
Hochtief Niederlassung Bayern  
LUSSEMBURGO  
WGZ Bank

SPAGNA

Hotel Valencia Palace Valencia  
Hotel San Roque Tenerife  
Caya General de Ahorros  
Granada

NORVEGIA

FRANCIA  
AUSTRIA  
SVIZZERA  
PORTOGALLO  
FINLANDIA

NORD AMERICA E AMERICA LATINA

---

MESSICO

VENEZUELA  
COLOMBIA  
PERU'  
URUGUAY  
COSTARICA

STATI UNITI

Citibank Offices  
Sony Lobby  
Ann Taylor Shops  
Bergdorf Goodmann  
Barney's New York  
Daniel Day Lewis  
Don Johnson  
Jennifer Lopez

OCEANIA

---

AUSTRALIA

Bally Shop  
Polo Ralph Lauren  
Deutsche Bank  
Citibank Limited  
Reader's Digest  
Sony Music  
University of Technology of Sidney  
Museum of Applied Arts & Sciences  
Telecom Australia Ltd  
Prospect Electricity Sidney  
Crown Casino Melbourne

NEW ZEALAND

MAURITIUS

ASIA\_MEDIO ORIENTE

---

KUWAIT

ISRAELE  
CIPRO  
TURCHIA  
EMIRATI ARABI  
ARABIA SAUDITA  
Happy Land Project

LIBANO

Credit Commercial de France Beirut

ASIA\_ESTREMO ORIENTE

---

MALESIA

Musictheque Istana  
Hotel Kuala Lumpur

SINGAPORE

Rabo Bank  
Government of Singapore  
Guess Boutique  
Siemens

Hong Kong

Sithe Asia

GIAPPONE

Pachinko Tower Tokyo

TAIWAN

COREA  
INDONESIA

Alivar si riserva la facoltà di apportare  
modifiche tecniche ai propri prodotti.  
Sono possibili differenze di colore  
dovute dalla tecnica di stampa.

Alivar reserves the right to change its  
products without notice. Printed  
catalogue colours may lightly differ.

A.D. Adriani & Rossi Edizioni  
Foto Studio Indoor  
Fotolito Comer  
Stampa Arbe Industrie Grafiche

Printed in Italy Aprile 2010

**SINCERT**



**ALIVAR**

Alivar s.r.l. - Via L. Da Vinci, 118/14  
50028 Tavarnelle Val di Pesa - Firenze - Italy  
t +39 055 8070115 f +39 055 8070127  
[www.alivar.com](http://www.alivar.com) [alivar@alivar.com](mailto:alivar@alivar.com)