

**ALIVAR**

Via B. Cellini,190 - 50028 Tavarnelle Val di Pesa - Firenze Italy tel. +39 055 8070115 fax +39 055 8070127 www.alivar.com e-mail: alivar@alivar.com

**ALIVAR** 04



04 Brilliant Furniture

ALIVAR

Ricordarsi e dimenticare assomiglia al lavoro del giardiniere scrive Marc Augé nel suo ultimo saggio (Les formes de l'oubli, Manuels Payot, Paris,1998). "I ricordi sono come le piante: ce ne sono alcune che bisogna eliminare molto rapidamente per aiutare le altre a crescere. Ma anche la crescita delle piante è una sorta di continuo oblio: il fiore è la dimenticanza del seme". Il lavoro del designer, nel suo continuo oscillare tra memoria e oblio, assomiglia perciò a quello del giardiniere. Sovente nel progetto la memoria è inconsapevole.

Perché spesso accade che le forme risorte siano involontarie, come se esistesse un abaco a cui tutti prima o poi si approvigionano, quasi che i segni siano immanenti, più che generati dalla mano di un designer. Nel progetto Brilliant Furniture di Bruno Rainaldi per Alivar la memoria è invece volontaria, coltivata nella consapevolezza che senza radici le piante non crescono, il razionalismo, la scuola del Bauhaus sono una memoria che bisogna dimenticare per poi ritrovare. Dimenticare per non esserne sopraffatti. E ritrovare per dare una ragione a delle forme che vogliono trasmettere quell'aura. Rifarsi a quelle radici significa trovare il difficile equilibrio tra memoria e oblio, stabilendo una delicata oscillazione tra queste attitudini. Ricordo e dimenticanza, andata verso il passato e ritorno al futuro appaiono il ritmo del progetto di Bruno Rainaldi. Bisogna prendere le distanze per ritrovare le prossimità; guardarsi alle spalle per dare consistenza al presente.

La contemporaneità ha le sue radici nel movimento moderno. E quelle vanno salvaguardate: non copie di forme, ma recupero di memoria, ovvero delle idee e dei principi generatrici di quelle forme. E di nuovo conviene ritornare alla metafora del giardiniere. Le radici, perchè la pianta cresca sana e rigogliosa, non vanno scoperte, rivelate. Anzi conviene siano celate sotto la terra perchè le intemperie non le offendano. Nei pezzi di Bruno Rainaldi le radici storiche sono ben protette, nascoste, quasi invisibili, eppur linfa vitale del progetto. Affiorano per rivelare la loro presenza con discrezione, senza mettersi a nudo per imporre la loro presenza. La qualità di questo progetto consiste nel difficile equilibrio tra memoria e oblio. La vera eleganza ha sempre un vago sapore di memoria capace di sfumare gradatamente nell'oblio.

Memory and oblivion are comparable to the gardener, wrote Marc Augé in his last treatise (Les formes de l'oubli, Manuels Payot, Paris,1998). Memoires are like plants: there are some which must be swiftly eliminated to allow for the growth of others. But the cultivation of plants is also a type of continuous oblivion: "The flower is the result of forgetting the seed". The work of the designer, which is a form of continuous oscillation between memory and oblivion, can therefore be compared to that of the gardener. Often in the field of design memory is subconscious. It often being the case that the recreated forms are accidental, almost as if a hidden source exists into which everyone dips into at some time; almost as if the forms themselves are intrinsic rather than a creation of the designer himself. While in the Brilliant Future project of Bruno Rainaldi for Alivar, memory is voluntary and cultivated in the full awareness that without roots there can be no plants. Rationalism and the school of Bauhaus are a memory that has to be forgotten and then recalled and then recalled again. Forgotten so that they do not come to dominate. Re-found in order to justify the forms and their intrinsic meaning. Going back to those roots signifies reaching that complex harmony between memory and oblivion, and creating a delicate oscillation between these two currents. Memory and oblivion, towards the past and then back again to the future; these are the essential concepts of the Bruno Rainaldi project. The need to go backwards to be able to come forwards, looking back to give a kind of consistency to the present. Contemporary trends have their roots in the modern movement, and these must be maintained. Not merely copies of forms but the generating principles behind these forms. Thereby once again bringing into play the metaphor of the gardener. To ensure sturdy and healthy growth; roots must not be pulled up and revealed but they must rather be hidden under ground to protect them from the elements. Pieces by Bruno Rainaldi therefore feature historic and well protected roots which are well hidden and almost invisible, but which in fact provide the essential lifeline of the design. Their presence being only subtly revealed so as to ensure that they are never imposing. The intrinsic value of this design is in fact in this delicate balance between memory and oblivion. True elegance is always in some ways related to memory, which has the capacity for gently fading into oblivion.

Cristina Morozzi Milano, Gennaio 1999



## Brilliant Furniture

### TAVOLI E SEDIE / TABLES AND CHAIRS

Big Table	tavolo / table	08
Formal	tavolo / table	14
Vernissage	tavolo / table	20
Biplano	tavolo / table	26
Simple chair	sedia / chair	28
Simple armchair	poltroncina / armchair	30
Greta	sedia / chair	34

### CREDENZE, LIBRERIE E CONTENITORI / CUPBOARDS, CABINETS AND BOOKCASES

Container	contenitori / cabinets	40
Arthur	credenza / cupboard	50
Shelf-service	libreria / bookcase	58
Ibis	libreria / shelving	64

### IMBOTTITI / UPHOLSTERED FURNITURE

Boss	divani, poltrona e pouff / sofas, armchair and ottomans	76
Buddy Boss	divano, poltrona / sofa and armchair	82
Sbend	divano, poltrona / sofa and armchair	86
Cartesiano	elemento di seduta / seating element	94
Internos	poltrona / armchair	96
Onda	pouff / ottoman	104
Tech	panca / bench	110
Snake	panca / bench	114
Fortuna	poltrona / armchair	116
Lolly	poltroncina / armchair	120

### LETTI / BEDS

Boss Bed	letto / bed	126
----------	-------------	-----

### ACCESSORI / ACCESSORIES

Look at me	specchio / mirror	136
Quadrus	specchio / mirror	140
A.B. Normal	orologio / wall-clock	144
Finiture / finishing		148
Schemi tecnici / technical outlines		152

## Tavoli e sedie

*Tables and chairs*

I tavoli e le sedie abitano con naturalezza la casa contemporanea, in forme minime ed espressive che cercano il linguaggio nitido dei materiali monocromi.

Il bianco, luminoso e assoluto, il nero, equilibrato e forte, il metallo, la luce.

Ma anche il piacere antico del legno e del cuoio e l'indefinibile emozione del cristallo.

L'essenza del progetto ne rivela la forza.

Lo spazio dedicato al giorno ritrova le sue forme ideali, le riconosce, le offre per essere vissute.

The tables and chairs wonderfully blend in with the modern home setting, featuring a minimalist but highly expressive style, and the basic high-impact of plain coloured materials. Shiny bold white, harmonious black, metallic shade reflecting the light.

But also all the traditional qualities of wood and leather, and the timeless attraction of glass. Its strength lying in the design simplicity. The living area is thereby given a splendid balanced harmony for day-to-day living.





Tavolo / Table

B I G T A B L E

Design Roberto Lazzeroni

Tavolo. Gambe in  
piatto d'acciaio  
cromato o laccato.  
Piano in legno  
spessore 5 cm. laccato  
lucido, rovere o laccato  
laminato liquido.

Table. Legs made of flat  
steel, chrome-plated  
or painted.  
Wooden top thickness  
cm. 5 available  
in oak, glossy  
lacquered, or with  
liquid laminate paint.







Tavolo BIG TABLE nella versione con piano laccato lucido nero, sedie art. 769/S (designer E. Saarinen) con cuscino di seduta in cavallino, libreria SHELF SERVICE in finitura rovere tinto wengé.

BIG TABLE with glossy black lacquered top, chairs art. 769/S (designed by E. Saarinen) with seat covered in cow skin, SHELF SERVICE bookcase with wengé-stained tops.



Tavolo BIG TABLE nella versione con piano laccato lucido bianco L/W 280 - H 72 - P/D 90, sedia SIMPLE CHAIR. BIG TABLE with glossy white lacquered top L/W 280 - H 72 - P/D 90, SIMPLE chair.



Tavolo BIG TABLE nella versione con piano rovere tinto wengé L/W 180 - H 72 - P/D 90, sedia SIMPLE CHAIR. BIG TABLE with top in wengé-stained oak L/W 180 - H 72 - P/D 90, SIMPLE chair.



Tavolo / Table

F O R M A L

Design Daniele Lo Scalzo Moscheri

Tavolo. Base in  
massello di rovere.  
Piano in tamburato  
impiallacciato rovere.

Table. Base made  
of solid oak.  
Oak veneered top.





Tavolo FORMAL nella finitura rovere tinto wengé, sedie art. 874 (designer C. R. Mackintosh) finitura frassino tinto wengé e cuscino di seduta in nabuk.

FORMAL table in wengé-stained oak. Chairs art. 874 (designed by C. R. Mackintosh) in wengé-stained ash with leather seat.





Tavolo FORMAL nella finitura rovere tinto wengé, sedie SIMPLE chair rivestite in pelle, libreria SHELF SERVICE in finitura rovere tinto wengé.

FORMAL table in wengé-stained oak, SIMPLE chair covered in leather, SHELF SERVICE bookcase with wengé-stained tops.



Tavolo / Table

V E R N I S S A G E

Design Bruno Rainaldi

Tavolo. Base in tubo di acciaio verniciato. Piano in legno laccato opaco o laccato laminato liquido. Spessore 6 cm.

Table. Base made of painted steel tube. Matt lacquered wooden top or painted with a liquid laminate finish. Top thickness cm 6.



Tavolo VERNISSAGE nella versione con piano laccato grigio. VERNISSAGE table with grey lacquered top.





Tavolo VERNISSAGE nella versione con piano laccato bianco, sedie art. 704 (designer H. Bertola), lampada a sospensione art. 518 (designer M. Brandt) con saliscendi.



VERNISSAGE table with white lacquered top. Chairs art. 704 (designed by H. Bertola). Adjustable hanging lamp art. 518 (designed by M. Brandt) with saliscendi.





Tavolo VERNISSAGE nella versione con piano laccato lucido bianco. VERNISSAGE table with glossy white lacquered top.



Tavolo / Table

B I P L A N O

Design Pietro Arosio



Tavolo BIPLANO con piano superiore in cristallo e piano inferiore in legno laccato, sedie TANGO color tortora lucido.  
BIPLANO table. Upper top in glass, lower top in lacquered wood. TANGO chairs in glossy dove brown colour.



Tavolo ovale. Struttura in metallo verniciato. Piano superiore in cristallo spessore 15 mm. Piano inferiore in rovere o laccato lucido.

Oval table. Metal frame, painted. Upper top in glass 15 mm thick. Lower top in oak or glossy laquered.



Sedia / Chair

S I M P L E C H A I R

Design Roberto Lazzeroni



Sedia. Gambe in piatto di acciaio cromato o laccato. Scocca in legno rivestita in gomma poliuretana. Rivestimento in pelle o tessuto.

Chair. Chrome-plated or painted flat steel legs. Wooden shell covered in polyurethane foam. Leather or fabric covers.



Poltroncina / Armchair

S I M P L E A R M C H A I R

Design Roberto Lazzeroni

Poltroncina.  
Struttura in tubo  
d'acciaio cromato  
o laccato. Seduta e  
spalliera in gomma  
poliuretana e dacron,  
rivestite in pelle  
o tessuto.

Armchair.  
Chrome-plated  
or painted steel frame.  
Seat and back made of  
polyurethane foam and  
dacron. Leather or fabric  
covers.







Poltroncina SIMPLE ARMCHAIR nella versione con struttura in acciaio e rivestimento in pelle.

SIMPLE ARMCHAIR with chrome-plated frame and leather cover.

Sedia / Chair

G R E T A

Design Leonardo Rossano

Sedia impilabile.  
Struttura in tubo  
d'acciaio cromato  
o laccato. Seduta  
e spalliera in rovere  
o laccate opaco.

Chair. Frame in  
chrome-plated or  
painted tubular steel.  
Seat and back in oak  
or matt lacquered.







Sedia GRETA nei colori laccati bianco, rosso vivo e in finitura rovere tinto wengé.

GRETA chair in wengé-stained oak or lacquered white or red.

## **Credenze, contenitori e librerie**

*Cupboards, cabinets and bookcases*

Ogni complemento è anche un simbolo di casa, senza il quale l'ambiente domestico non sarebbe lo stesso. La linea pura dona piena evidenza ai materiali e ogni forma risponde al bisogno attuale di un design minimale ed espressivo, tratti inconfondibili dello stile Alivar.

Each element intrinsically reflects the spirit of the home, making a harmonious whole. The pure lines enhance the quality of the materials used, in clearly minimalist, yet highly expressive style, reflecting the Alivar design philosophy.





Contenitore / Cabinet

C O N T A I N E R

Design Bruno Rainaldi

Contenitore. Base in acciaio e contenitore in legno, entrambi laccati in laminato liquido o laccato lucido. Ripiani in legno o cristallo.

Cabinet. Steel frame + wooden cabinet, both painted with a liquid laminate finish or glossy lacquered. Shelves in wood or glass.







Contenitore CONTAINER laccato tortora lucido. Poltrona art. 334 e poggiatesta art. 336 (designer L. Mies Van Der Rohe) in pelle nera.  
CONTAINER cabinet in glossy dove brown colour. Armchair art. 334 and ottoman art. 336 in black leather (designed by L. Mies Van Der Rohe).





Contenitore CONTAINER laccato lucido rosso vivo. Tavolo art. 769/7 e sedia art. 769/S (designer E. Saarinen).  
CONTAINER cabinet in glossy red colour. Table art. 769/7 and chair art. 769/S (designed by E. Saarinen).





Contenitore CONTAINER laccato lucido nero. Tavolo art. 769/7 e sedie art. 769/S (designer E. Saarinen).  
CONTAINER cabinet in glossy black colour. Table art. 769/7 and chair art. 769/S (designed by E. Saarinen).



Contenitore CONTAINER L 42 H 188 cm, nella versione laccata in vari colori.

CONTAINER cabinet W 42 H 188 cm, lacquered in different colours.

Credenza / Cupboard

A R T H U R

Design Bruno Rainaldi

Madia in rovere  
disponibile nelle seguenti  
finiture:

- Tutta in rovere.
- Piano e contenitori  
in rovere + ante  
laccate lucide.
- Tutta laccata lucida.

Cupboard in oak wood,  
available in the  
following finishes:

- Oak.
- Top and cabinets in  
oak + glossy  
lacquered doors.
- Glossy lacquered.

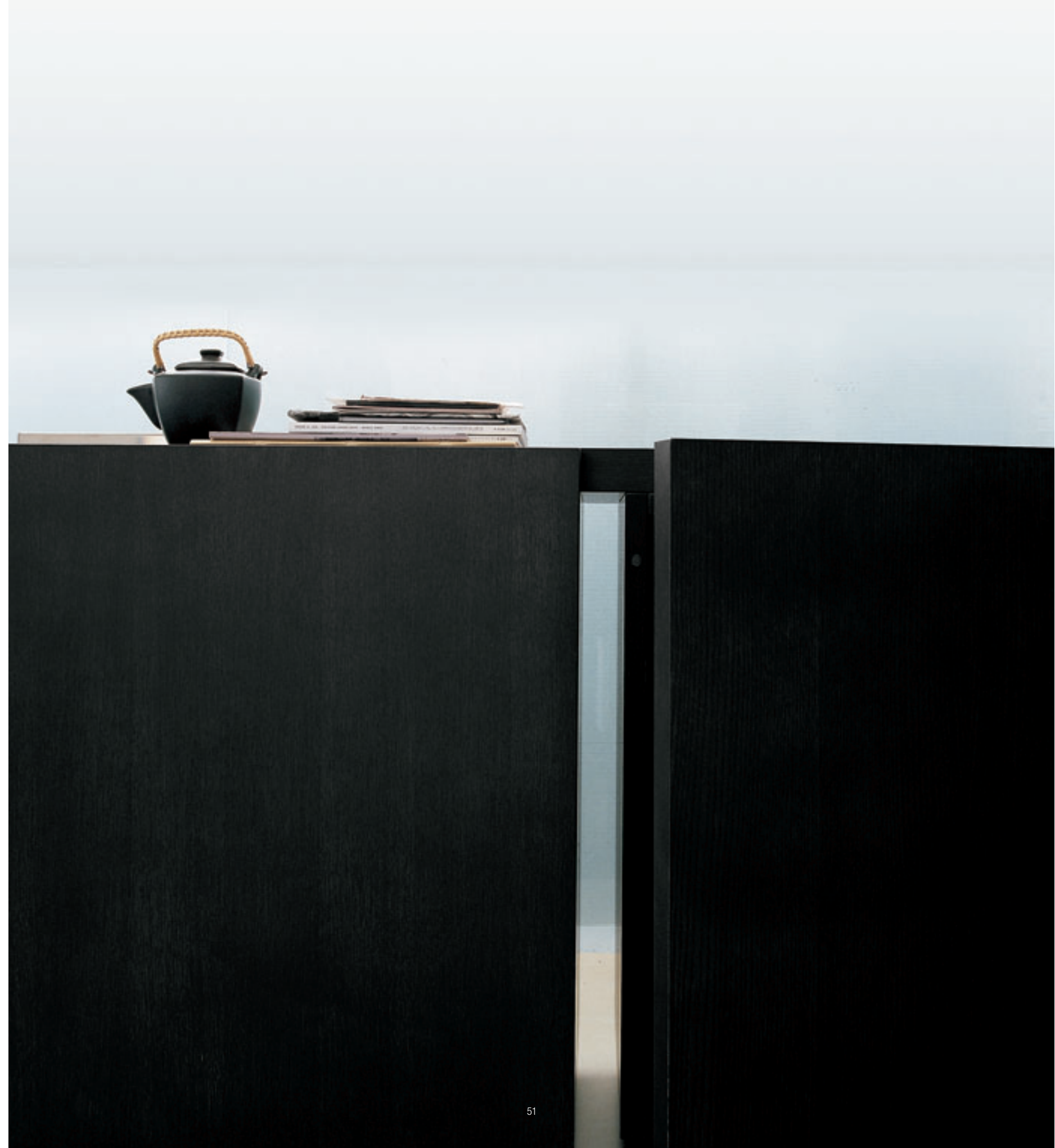





Madia ARTHUR in finitura rovere tinto wengé. Tavolo art. 769/7 e sedie art. 769/S (designer E. Saarinen), specchiera LOOK AT ME. ARTHUR cupboard in wengé-stained oak. Table art. 769/7 and chairs art. 769/S (designed by E. Saarinen), LOOK AT ME mirror.







Contenitore ARTHUR laccato lucido tortora. Poltrona art. 325 (designer L. Mies Van Der Rohe). ARTHUR cabinet in glossy dove brown colour. Chair art. 325 (designed by L. Mies Van Der Rohe).



Libreria / Bookcase

S H E L F - S E R V I C E

Design Bruno Rainaldi

Libreria componibile.  
Struttura in acciaio  
laccato o cromato.  
Ripiani in legno  
disponibili nelle seguenti  
finiture: laccato lucido,  
laminato liquido, laccato  
opaco, rovere.

Sectional bookcase.  
Frame in chrome-plated  
or painted steel.  
Wooden shelves  
available in the  
following finishes:  
glossy lacquered,  
liquid laminate,  
matt lacquered, oak.



Libreria SHELF-SERVICE in finitura rovere tinto wengé, sedia SIMPLE CHAIR e tavolo in cristallo art. 229 (designer Le Corbusier).  
SHELF-SERVICE bookcase in wengé-stained oak. SIMPLE chair.  
Table with glass top art. 229 (designed by Le Corbusier).





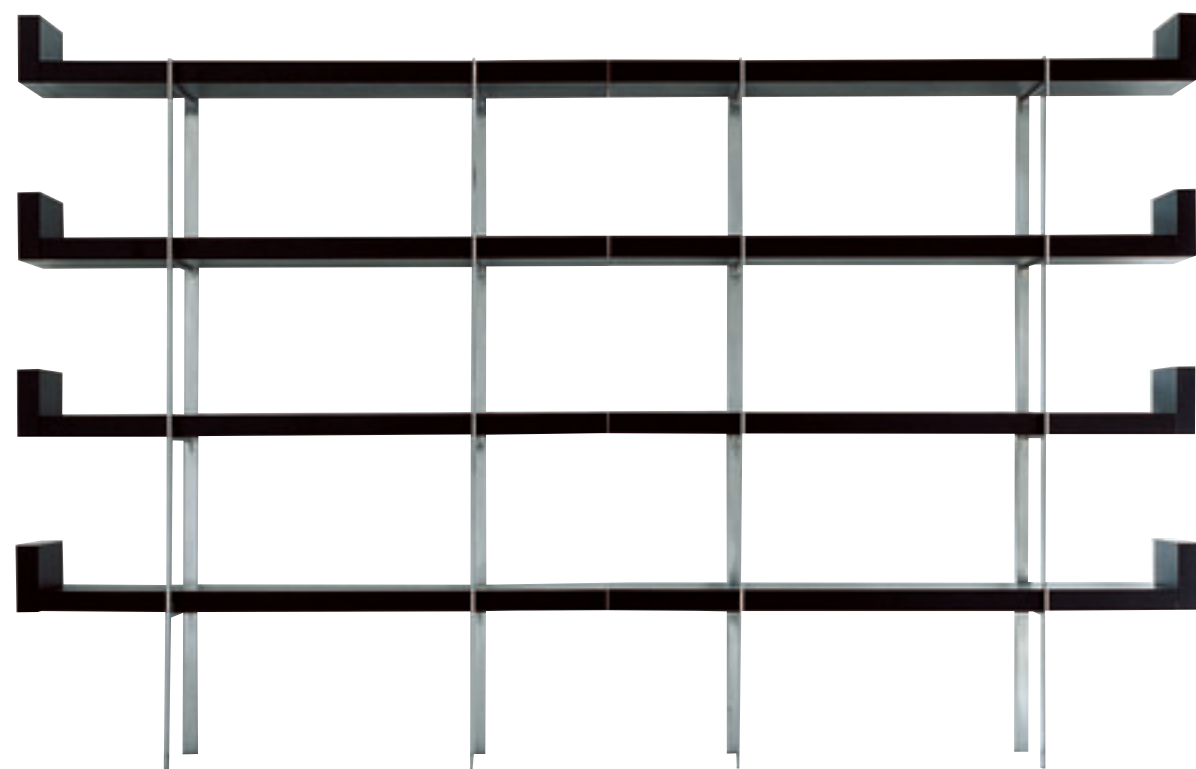

Libreria SHELF-SERVICE nelle versioni laccata nera o bianca L 330.

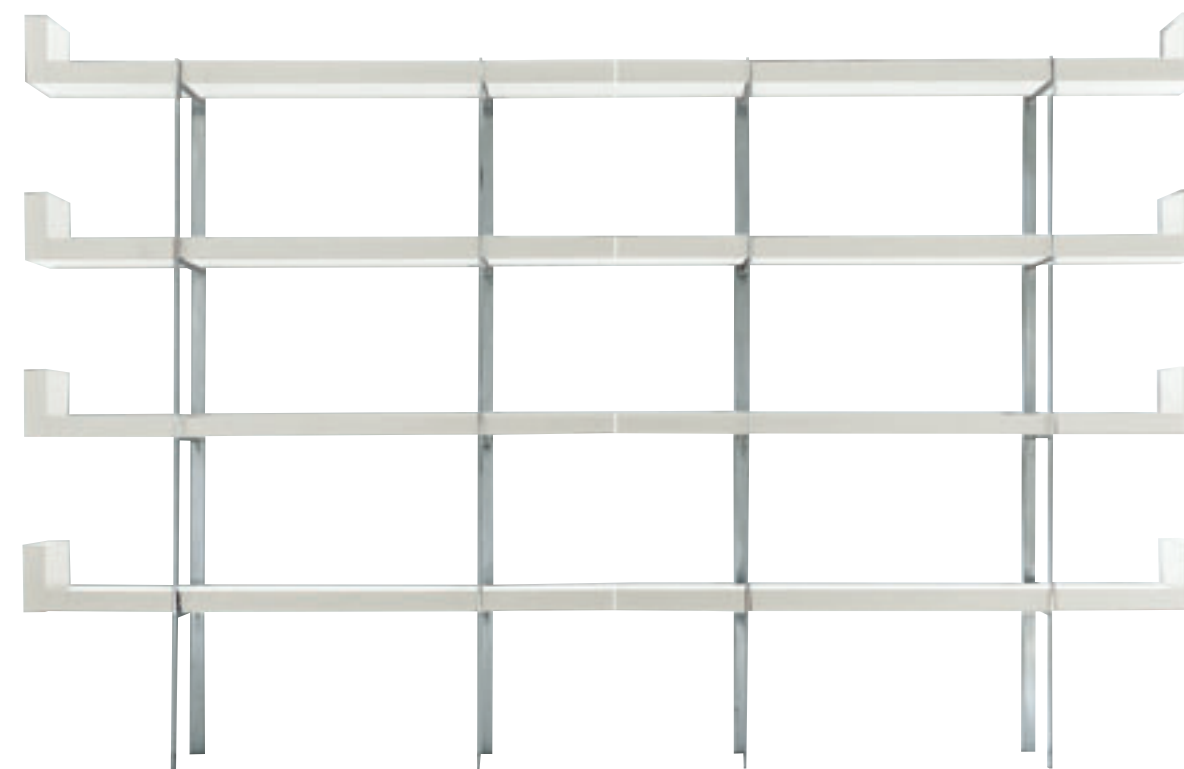

SHELF-SERVICE bookcase with black or white lacquered tops (W cm 330).

Librerie / Shelving

I B I S

Design Theo Beunen

Libreria. Staffa di supporto per fissaggio al muro in acciaio laccato. Cavi autofilettanti in acciaio inox di varie misure. Accessori: ripiani e contenitori in rovere naturale, sbiancato, tinto ciliegio, tinto wengé o laccato laminato liquido o laccato lucido. I ripiani possono essere anche in cristallo temperato, trasparente o colorato.

Shelving. Support bracket for wall fixing in painted steel. Self-threading stainless steel cables in various sizes. Shelves and cabinets in natural, bleached or wengé-stained oak or stained cherry or glossy lacquered or painted in liquid laminate. The shelves are available in tempered clear glass or colored glass.







Libreria IBIS con ripiani in vetro colorato nero, pouff ONDA. IBIS shelving with black coloured glass top, ONDA ottoman.



Libreria IBIS con ripiani in finitura rovere tinto wengé. IBIS shelving with wengé-stained oak tops.







Libreria IBIS con ripiani in finitura rovere tinto wengé, divano in pelle art. 633 (design di G. Hoffmann) con imbottitura in wengé-stained oak tops. Sofa covered in leather art. 633 (design by G. Hoffmann)









## **Imbottiti**

### *Upholstered furniture*

Lasciarsi accogliere da una casa è come iniziare un nuovo percorso di conoscenza. Gli imbottiti sono essenziali ma fortemente significativi, pezzi unici che creano lo stile di un'eleganza esclusiva. Il bianco, il nero concedono rarefatti spazi al colore e ogni particolare è un segno di valore. La pelle segue il ritmo decorativo delle impunture e il fascino attuale del metallo, i tessuti rivestono linee più morbide e avvolgenti.

With all the welcoming embrace of a comfortable home setting. The padded range is basic, yet highly expressive, unique furnishing elements which create an exclusive elegance. With white and black dominating, with the odd splashes of colour, each detail is a mark of quality. The leather following the decorative harmonic perfection of the stitching, enhancing the sleekness of the metal, while the fabrics lend a softer and warmer touch.



Divani, poltrona e pouff / Sofas, armchair and ottomans

B O S S

Design Bruno Rainaldi

Poltrona. Struttura in acciaio rivestita in poliuretano. Base in tubo di acciaio verniciato alluminio gofrato. Rivestimento in pelle o tessuto.

Armchair. Steel frame covered with polyurethane foam. Base in steel tube painted embossed aluminium. Covered in fabric or leather.







Divani Boss in pelle nera. Tavolino con piano in cristallo art. 269 (designer Le Corbusier) libreria IBIS con ripiani in legno.

BOSS sofas in black leather. Low table with glass top art. 269 (designed by Le Corbusier). IBIS shelving with wooden shelves.





Divano e pouff BOSS in pelle nera. BOSS sofa and ottomans in black leather.



Poltroncina / Armchair

B U D D Y B O S S

Design Bruno Rainaldi

Poltroncina. Struttura in acciaio rivestita in poliuretano. Base in tubo di acciaio cromato o laccato. Rivestimento in pelle o tessuto.

Armchair. Steel frame covered with polyurethane foam. Base in chrome-plated or painted steel. Covered in fabric or leather.





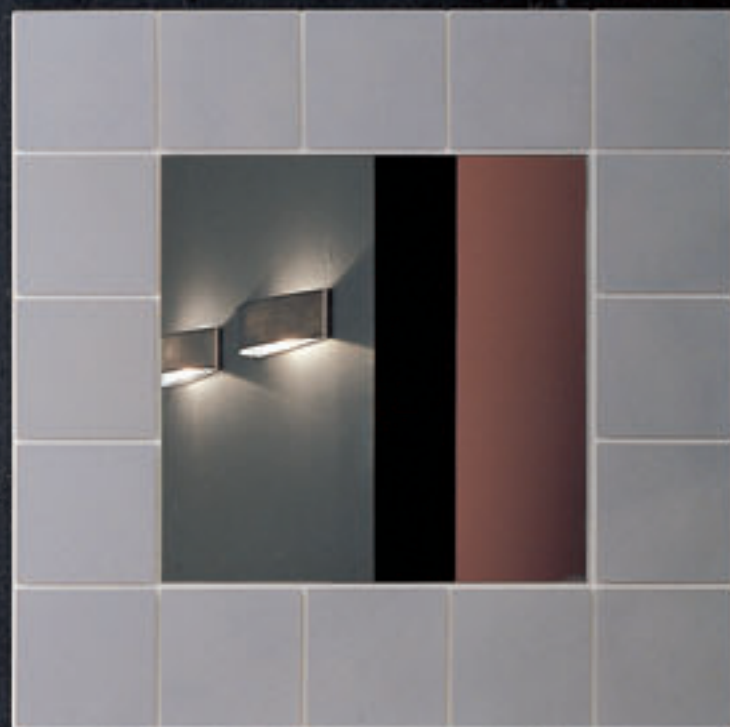

Divanetto e poltroncine BUDDY BOSS in pelle, specchio QUADRUS. BUDDY BOSS armchairs and sofa, covered in leather. QUADRUS mirror.



Divano / Sofa

S B E N D

Design Bruno Rainaldi

Divano. Struttura in legno ricoperta in gomma poliuretana e dacron. Rivestimento in tessuto o pelle. Piedi in acciaio verniciato.

Sofa. Wooden frame covered in polyurethane foam and dacron. Leather or fabric covers. Painted steel feet.







Divano SBEND rivestito in tessuto, libreria IBIS in rovere tinto wengé. SBEND sofa covered in fabric. IBIS shelving in wengé-stained oak.



Divano SBEND rivestito in tessuto, libreria IBIS in rovere tinto wengé. SBEND sofa covered in fabric, IBIS shelving in wengé-stained oak.







Divano SBEND nella versione con rivestimento in tessuto o pelle.



SBEND sofa covered in fabric or leather.

CARTESIANO

Design Claudio Bitetti

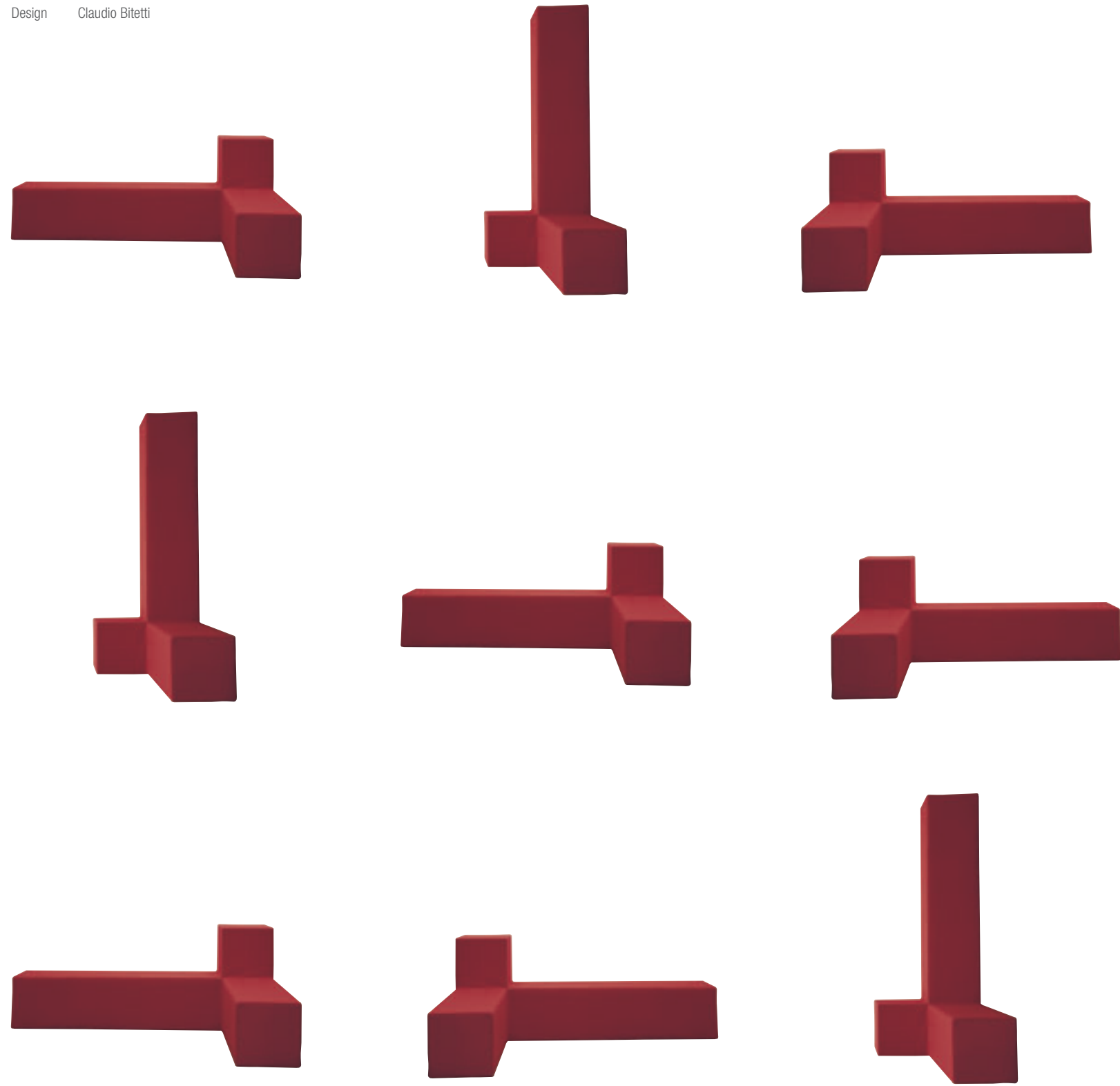

Struttura in acciaio ricoperta in gomma poliuretana. Rivestimento in tessuto sfoderabile. Steel frame covered with polyurethane foam. Removable fabric cover.





Poltroncina / Armchair

I N T E R N O S

Design Bruno Rainaldi

Poltroncina. Struttura in legno ricoperta in gomma poliuretana e dacron. Rivestimento in tessuto o pelle. Piedi cromati.

Armchair. Wooden frame covered in polyurethane foam and dacron. Leather or fabric covers. Chrome-plated feet.





Poltroncine INTERNOS nella versione in pelle. INTERNOS armchairs with leather cover.







Poltroncine INTERNOS nella versione in tessuto in vari colori.

INTERNOS armchairs covered in fabric in different colours.



Poltroncine INTERNOS nella versione in pelle. Tavolino art. 799 (designer I. Noguchi).

INTERNOS armchairs covered in leather. Low table art. 799 (designed by I. Noguchi).



Pouff / Ottoman

O N D A

Design Fabio Bortolani

Pouff. Struttura in legno ricoperta in poliuretano e dacron.  
Rivestimento in pelle o tessuto completamente sfoderabile.  
Base in acciaio laccato alluminio.

Ottoman. Wooden frame covered with polyurethane foam and dacron. Removable leather or fabric covers.  
Aluminium painted steel base.







Pouff ONDA in pelle bianca e cuscino in pelle nera. Paravento art. 400 (designer E. Gray).

ONDA ottoman covered in white leather. Screen art. 400 (designed by E. Gray).



Pouff ONDA in tessuto. ONDA ottoman covered in fabric.



Panca / Bench

T E C H

Design Matteo Scandola



Panca.  
Struttura in  
acciaio cromato  
o laccato. Seduta  
imbottita in gomma  
poliuretanaica.  
Rivestimento  
in pelle o tessuto.

Bench.  
Steel frame,  
chrome-plated  
or painted.  
Seat made  
of polyurethane foam.  
Leather or fabric cover.





Panca / Bench

T E C H

Design Matteo Scandola



Panca TECH con imbottitura in pelle nera e bianca. TECH bench with white or black leather covers.

Panca. Struttura in acciaio cromato o laccato. Seduta imbottita in gomma poliuretana. Rivestimento in pelle o tessuto.

Bench. Steel frame, chrome-plated or painted. Seat made of polyurethane foam. Leather or fabric cover.

P a n c a / B e n c h

S N A K E

Design Matteo Scandola



Panca curviforme accostabile all'infinito. Accostando gli elementi tra di loro si possono creare insolite sedute di forma sinusoidale. Struttura in acciaio cromato o laccato. Seduta imbottita in gomma poliuretanaica. Rivestimento in pelle o tessuto sfoderabile. Tavolino di collegamento in alluminio verniciato.

Infinite approach curvilinear bench. By combining the elements together, it is possible to create unusual seating arrangements of sinusoidal form. Steel frame, chrome-plated or painted. Seat made of polyurethane foam. Removable leather or fabric covers. Connecting side table in painted aluminium.



Poltrona / Armchair

F O R T U N A

Design Pietro Arosio



Poltrona. Struttura in legno massello ricoperta in poliuretano e dacron. Rivestimento in pelle o tessuto.

Armchair. Frame in solid wood covered with polyurethane foam and dacron. Leather or fabric cover.





Poltrone FORTUNA rivestite in cavallino. FORTUNA armchairs covered in cow skin.



Poltroncina / Armchair

L O L L Y

Design Daniele Lo Scalzo Moscheri

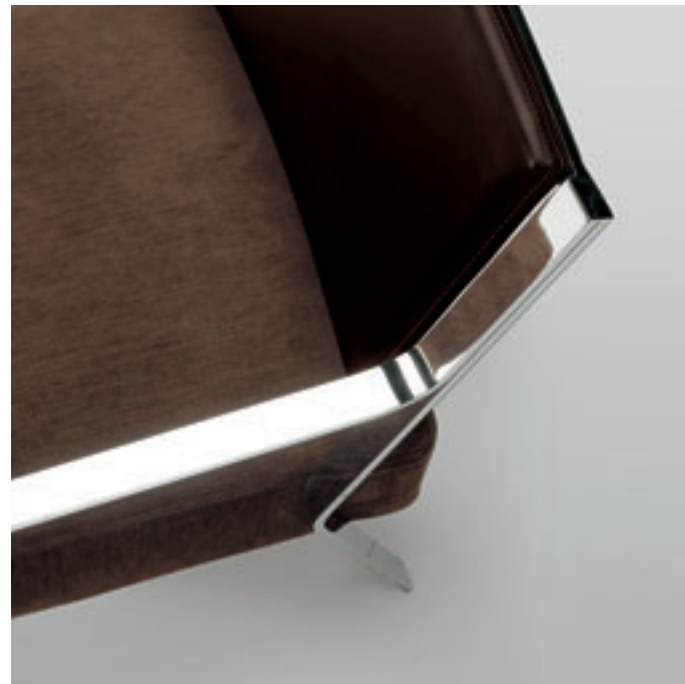

Poltroncina. Struttura in piatto di acciaio cromato o verniciato. Cuscino seduta in poliuretano e dacron rivestito in tessuto o pelle. Spalliera in cuoio.

Armchair. Frame made of painted or chrome-plated flat steel. Upholstered seat cushion, covered in leather or fabric. Back covered in hide.





Poltroncine LOLLY nella versione in pelle nera. LOLLY armchairs covered in black leather.







### **Letti** *Beds*

La testata imbottita e trapuntata rivela le sensazioni visive e tattili delle impunture capitonné sulla pelle. La geometria della base in acciaio ci rammenta la scrupolosa ricerca rivolta ai materiali e al dinamismo spaziale delle forme.

The padded headrest is quilted to give all the visual and tactile sensations of stitching on the leather. The sleek geometric perfection of the steel frame, highlights the ongoing commitment to material quality excellence and dynamic spatial forms.



Letto / Bed

B O S S B E D

Design Bruno Rainaldi

Letto con testata capitonné. Struttura in acciaio rivestita in espanso. Base in tubo di acciaio verniciato alluminio gofrato. Rete con doghe in faggio. Disponibile in varie misure.

Bed with quilted headboard. Steel frame covered with polyurethan foam. Base in steel tube painted embossed aluminium. Beechwood slats. Available in different sizes.







Letto in pelle BOSS BED MEDIUM. Tavolino art. 769/3 (designer E. Saarinen). Panca TECH in pelle.  
BOSS BED MEDIUM. Side table art. 769/3 (designed by E. Saarinen). TECH bench covered in leather.





Letto in pelle BOSS BED LOW. BOSS BED LOW covered in leather.



Letto in pelle BOSS BED MEDIUM. BOSS BED MEDIUM covered in leather.





Letto in pelle BOSS BED WIDE. BOSS BED WIDE covered in leather.



**Accessori** *Accessories*

La collezione Alivar elegge alcuni oggetti di design, come l'orologio, lo specchio: oggetti espressivi, tocchi di classe per l'ambiente che li accoglie.

The Alivar collection has also selected some impeccable design objects, such as the clocks and mirrors: objects of sheer expression and which add an added touch of class to the surroundings.



Specchio / Mirror

LOOK AT ME

Design Bruno Rainaldi con Andrea Salveti

Specchiera a parete  
con cornice in  
fusione di alluminio  
decorata a mano con  
deco floreal a rilievo di  
provenienza  
rinascimentale.

Mirror.  
Frame in cast  
aluminium with  
renaissance floreal  
hand-decoration in relief.







Specchi singoli LOOK AT ME. Poltrone art. 334 in pelle nera (designer L. Mies Van Der Rohe). Libreria IBIS. LOOK AT ME single mirrors. Armchairs covered in black leather art. 334 (designed by L. Mies Van Der Rohe). IBIS shelving.



Specchio / Mirror

QUADRUS

Design Bruno Rainaldi



Specchio composto da pannello in legno laccato con attacco a parete (sia verticale che orizzontale) e da quadri in lamiera laccati distanziati di 1 cm.

Mirror made of a white wooden panel with wall attachment (vertical and horizontal) and squares in painted steel sheet at 1 cm.



Specchi QUADRUS. Poltrone art. 871 (designer C. R. Mackintosh). QUADRUS mirror. Armchairs art. 871 (designed by C. R. Mackintosh).

Specchio QUADRUS singolo. QUADRUS single mirror.





Orologio / Wall-clock

A B N O R M A L

Design Bruno Rainaldi

Orologio a parete in lamiera di acciaio verniciato bianco o alluminio con meccanismo a pila.

Wall-clock made of steel plate, painted white or aluminium. Battery mechanism.





Orologio AB NORMAL verniciato bianco. Divano BOSS in pelle bianca. AB NORMAL clock, painted white. BOSS sofa covered in white leather.





ESSENZE / WOOD



rovere sbiancato\_bleached oak



rovere tinto nero\_black-stained oak



rovere tinto wengé\_wengé-stained oak

LACCATURE PER METALLO / STEEL LACQUERS



alluminio gofrato\_embossed aluminium



alluminio cromo\_alu-chrome

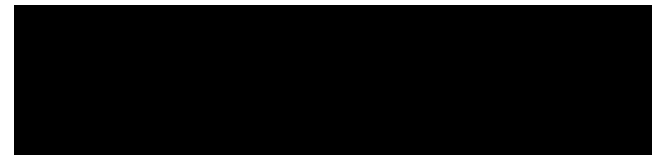

RAL 9005 / nero opaco\_matt black



RAL 9016 / bianco ottico\_optical white



20.50 / verde\_green



40.20 / rosso scuro\_dark red



RAL 3003 / rosso vivo\_bright red



05.45 / grigio\_grey



50.40 aragosta\_lobster colour



RAL 2001 / arancio\_orange



05.70 / tortora\_dove brown

LACCATURE PER LEGNO / WOOD LACQUERS



RAL 9005 / nero opaco\_matt black      RAL 9005 / nero lucido\_glossy black



RAL 9016 / bianco opaco\_matt white      RAL 9016 / bianco lucido\_glossy white



05.70 / tortora opaco\_matt dove brown      05.70 / tortora lucido\_glossy dove brown



20.50 / verde opaco\_matt green      20.50 / verde lucido\_glossy green



05.45 / grigio opaco\_matt grey      05.45 / grigio lucido\_glossy grey



RAL 2001 / arancio opaco\_matt orange      RAL 2001 / arancio lucido\_glossy orange



40.20 / rosso scuro opaco\_matt dark red      40.20 / rosso scuro lucido\_glossy dark red



RAL 3003 /rosso vivo opaco\_matt bright red      RAL 3003 /rosso vivo lucido\_glossy bright red



50.40 aragosta opaco\_matt lobster colour      50.40 aragosta lucido\_glossy lobster colour

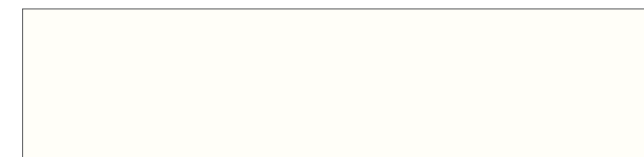

laminato liquido bianco\_white liquid laminate



laminato liquido nero\_black liquid laminate

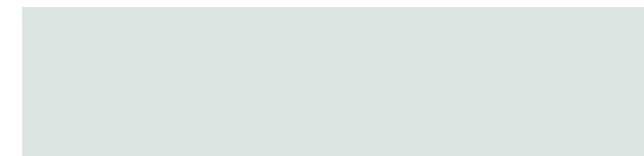

laminato liquido grigio chiaro\_light grey liquid laminate

CRISTALLO / GLASS



cristallo trasparente\_clear glass

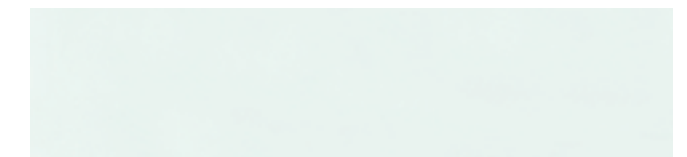

cristallo sabbiato\_sand-blasted glass



cristallo verniciato blu\_blue painted glass



cristallo verniciato verde acqua\_sea-green painted glass



cristallo verniciato arancio\_orange painted glass



cristallo nero\_black-painted glass



BIG TABLE

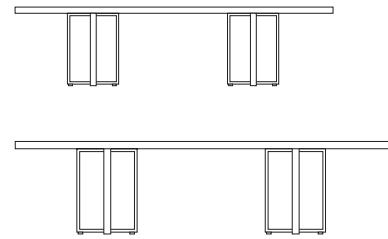

L/W 180 P/D 90 H 72  
W 70,9" D 35,4" H 28,3"

L/W 220/280 P/D 90 H 72  
W 86,6"/110,2" D 35,4" H 28,3"

FORMAL

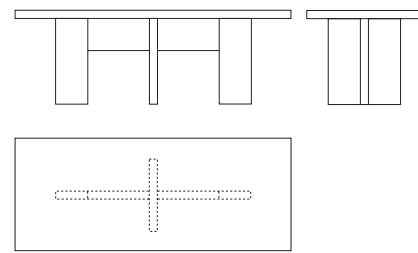

L/W 240 P/D 90 H 73 art. 4109  
L/W 280 P/D 90 H 73 art. 4119

W 94,5" D 35,4" H 28,7" art. 4109  
W 110,2" D 35,4" H 28,7" art. 4119

VERNISSAGE

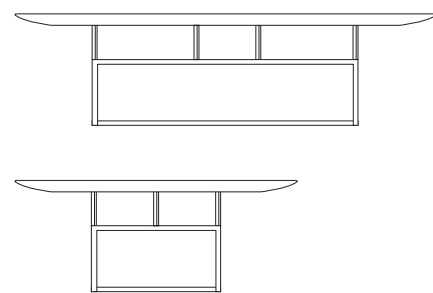

L/W 220 P/D 100 H 73 art. 9009/A  
L/W 150 P/D 150 H 73 art. 9009/B  
L/W 240 P/D 120 H 73 art. 9009/D  
L/W 280 P/D 120 H 73 art. 9009/C  
W 86,6" D 39,4" H 28,7" art. 9009/A  
W 59" D 59" H 28,7" art. 9009/B  
W 94,5" D 47,2" H 28,7" art. 9009/D  
W 110,2" D 47,2" H 28,7" art. 9009/C

BIPLANO

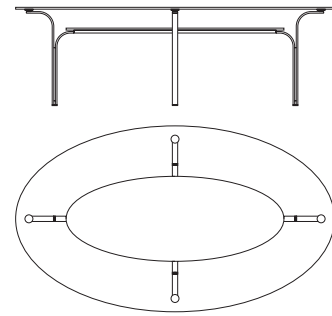

L/W 240 P/D 140 H 74 art. 4019  
L/W 280 P/D 140 H 74 art. 4019/A

W 94,5" D 55,1" H 29,1" art. 4019  
W 110,2" D 55,1" H 29,1" art. 4019/A

SIMPLE CHAIR

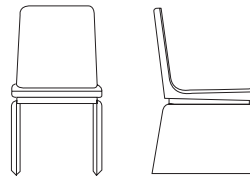

L/W 44,5 H 86,5 P/D 57  
W 17,5" H 34" D 22,4"

SIMPLE ARMCHAIR

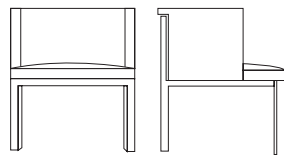

L/W 61 H 74,5 P/D 65  
W 24" H 29,3" D 25,6"

GRETA

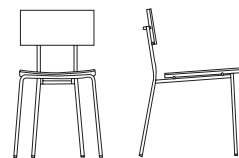

L/W 49,3 H 80,8 P/D 56,5  
W 19,4" H 31,8" D 22,2"

CONTAINER

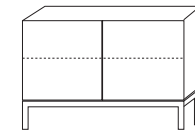

art. 9095  
L/W 130 P/D 42 H 85  
W 51,2" D 16,5" H 33,5"

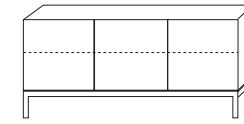

art. 9096  
L/W 195 P/D 42 H 85  
W 76,8" D 16,5" H 33,5"

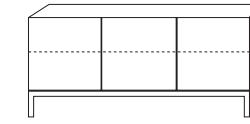

art. 9083/A\*  
L/W 225 P/D 42 H 95  
W 88,6" D 16,5" H 37,4"

\*articolo in esaurimento  
article stocks running out

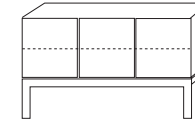

art. 8073/A  
L/W 126 P/D 42 H 62  
W 49,6" D 16,5" H 24,4"

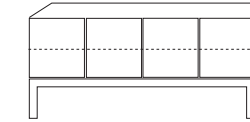

art. 8094/B  
L/W 168 H 62 P/D 42  
W 66,1" H 24,4" D 16,5"



art. 8064/A  
L/W 42 H 188 P/D 42  
W 16,5" H 74" D 16,5"



art. 9081/A\*  
L/W 75 P/D 42 H 170  
W 29,5" D 16,5" H 66,9"



art. 9097  
L/W 65 P/D 42 H 150  
W 25,6" D 16,5" H 59"

\*articolo in esaurimento  
article stocks running out

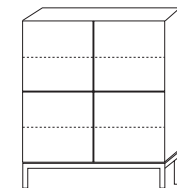

art. 9084/A\*  
L/W 150 P/D 42 H 170  
W 59" D 16,5" H 66,9"

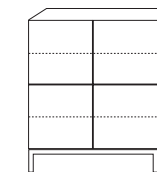

art. 9098  
L/W 130 P/D 42 H 150  
W 51,2" D 16,5" H 59"

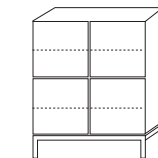

art. 8074/A  
L/W 84 P/D 42 H 104  
W 33" D 16,5" H 40,9"

\*articolo in esaurimento  
article stocks running out

ARTHUR

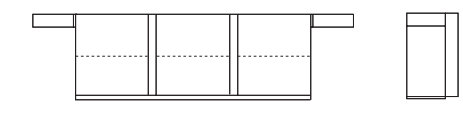

art. 9051  
L/W 300 P/D 45 H 85  
W 118,1" D 17,7" H 33,5"



art. 9053  
L/W 215 P/D 45 H 120  
W 84,6" D 17,7" H 47,2"

art. 9056  
L/W 215 P/D 45 H 85  
W 84,6" D 17,7" H 33,5"

SHELFSERVICE

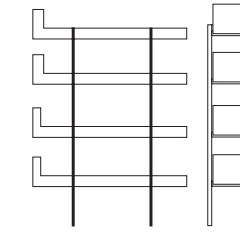

art. 9100 SX/DX  
L/W 165 P/D 40 H 188 SX/DX  
W 65" D 15,7" H 74" (left or right)

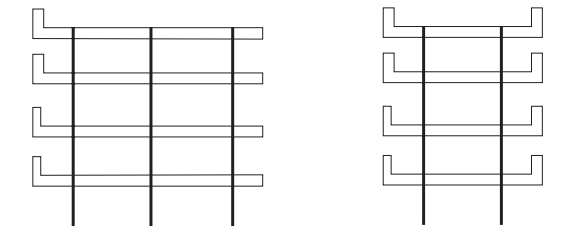

art. 9206 DX/SX  
L/W 237 P/D 40 H 188 DX/SX

art. 9204  
L/W 170 P/D 40 H 188  
W 66,9" D 15,7" H 74"

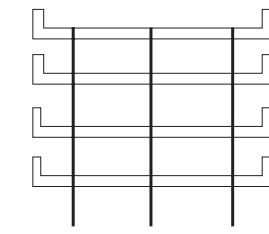

art. 9205  
L/W 242 P/D 40 H 188  
W 95,3" D 15,7" H 74"

Ripiano prof. cm. 34/13,4"  
Shelf depth cm. 34/13,4"

BOSS

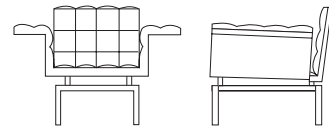

art. 9005  
L/W 123 P/D 75 H 80  
W 48,4" D 29,5" H 31,5"

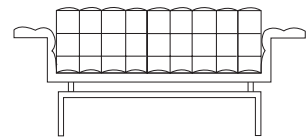

art. 9002  
L/W 195 P/D 75 H 80  
W 76,8" D 29,5" H 31,5"

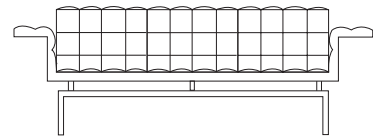

art. 9003  
L/W 240 P/D 75 H 80  
W 94,5" D 29,5" H 31,5"

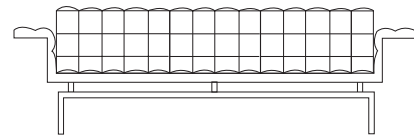

art. 9083  
L/W 270 P/D 75 H 80  
W 106,3" D 29,5" H 31,5"

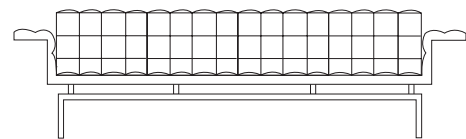

art. 9004  
L/W 300 P/D 75 H 80  
W 118,1" D 29,5" H 31,5"

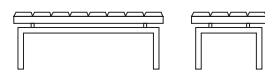

art. 9006  
L/W 120 P/D 60 H 43  
W 47,2" D 23,6" H 16,9"

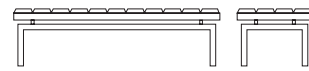

art. 9006/A  
L/W 160 P/D 60 H 43  
W 63" D 23,6" H 16,9"

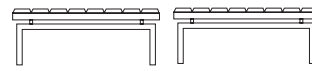

art. 9006/B  
L/W 120 P/D 120 H 43  
W 47,2" D 47,2" H 16,9"

BUDDY BOSS

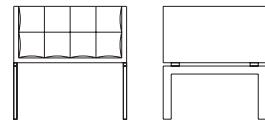

art. 9241  
L/W 71 H 75 P/D 65  
W 28" H 29,5" D 25,6"

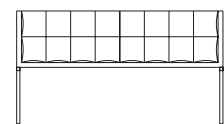

art. 9242  
L/W 127 H 75 P/D 65  
W 50" H 29,5" D 25,6"

SBEND

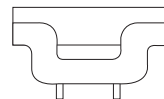

art. 9061  
L/W 120 P/D 85 H 81  
W 47,2" D 33,5" H 31,9"

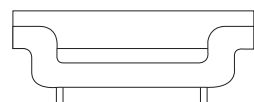

art. 9062  
L/W 180 P/D 85 H 81  
W 70,9" D 33,5" H 31,9"

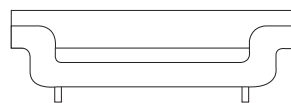

art. 9063  
L/W 210 P/D 85 H 81  
W 82,7" D 33,5" H 31,9"

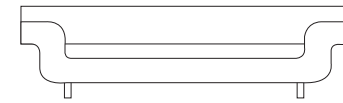

art. 9064  
L/W 240 P/D 85 H 81  
W 94,5" D 33,5" H 31,9"



art. 9063 cuscino / cushion  
L/W 55 P/D 55  
W 21,6" D 21,6"

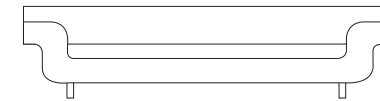

art. 9065  
L/W 270 P/D 85 H 81  
W 106,3" D 33,5" H 31,9"

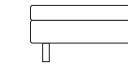

art. 9094/P  
L/W 107 P/D 107 H 43  
W 42,1" D 42,1" H 16,9"

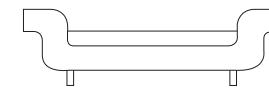

art. 9066  
L/W 190 P/D 60 H 62  
W 74,8" D 23,6" H 24,4"

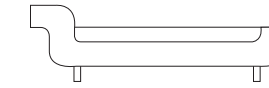

art. 9067  
L/W 210 P/D 70 H 62  
W 82,7" D 27,5" H 24,4"

CARTESIANO

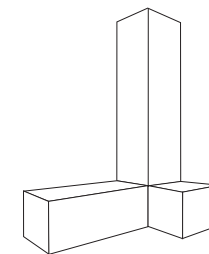

art. 9300  
L/W 150 P/D 90 H 231  
W 59" D 35,4" H 90,9"  
altezza seduta / seat height cm. 45 / 17,7"

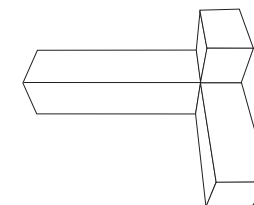

art. 9300  
L/W 231 P/D 150 H 90  
W 90,9" D 59" H 35,4"

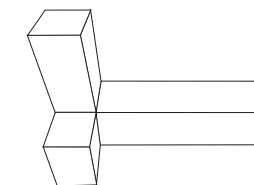

art. 9300  
L/W 231 P/D 90 H 150  
W 90,9" D 35,4" H 59"

INTERNOS

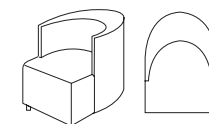

art. 9085  
L/W 67 H 70 P/D 80  
W 26,3" H 27,5" D 31,5"

ONDA



ONDA 1  
L/W 65 P/D 65 H 42  
W 25,6" D 25,6" H 16,5"



Cuscino / Cushion  
L/W 65 P/D 10 H 31  
W 25,6" D 3,9" H 12,2"



ONDA 2  
L/W 140 P/D 65 H 42  
W 55,1" D 25,6" H 16,5"

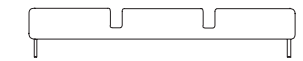

ONDA 3  
L/W 215 P/D 65 H 42  
W 84,6" D 25,6" H 16,5"

TECH

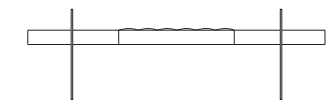

art. 5100  
L/W 215 P/D 59 H 41  
W 84,6" D 23,2" H 16,1"

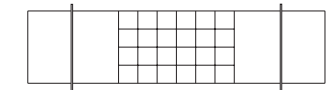

SNAKE

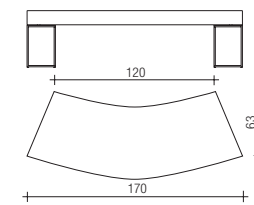

art. 5102  
L/W 170 P/D 63 H 44  
W 66,9" D 24,8" H 17,3"

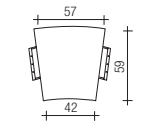

art. 5103  
L/W 57 P/D 42  
W 22,4" D 16,5"

FORTUNA

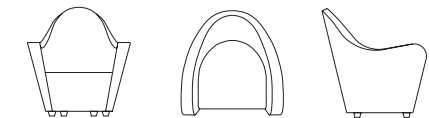

art. 4025  
L/W 85 H 94 P/D 87  
W 33,5" H 37" D 34,2"

LOLLY

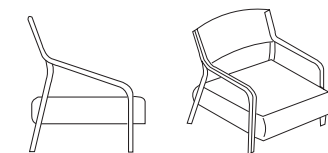

L/W 64 H 79 P/D 68  
W 25,2" H 31,1" D 26,8"



BOSS BED

Boss bed HIGH art. 9007

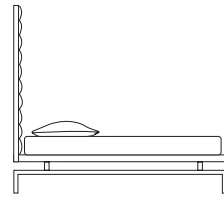
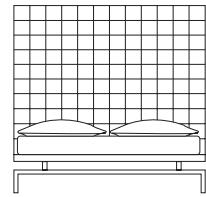

Standard	L/W 175	H 170	P/D 209	per materasso	L/W 170	P/D 197
	W 68,9"	H 66,9"	D 82,3"	for mattress	W 66,9"	D 77,5"
Queen-Size	L/W 161	H 170	P/D 215	per materasso	L/W 150	P/D 203
	W 63,4"	H 66,9"	D 84,6"	for mattress	W 59"	D 79,9"
King-Size	L/W 205	H 170	P/D 215	per materasso	L/W 193	P/D 203
	W 80,7"	H 66,9"	D 84,6"	for mattress	W 76"	D 79,9"
Europe	L/W 190	H 170	P/D 212	per materasso	L/W 180	P/D 200
	W 74,8"	H 66,9"	D 83,5"	for mattress	W 70,9"	D 78,7"

Boss bed MEDIUM art. 9087

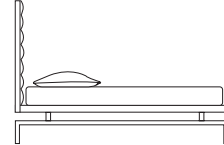
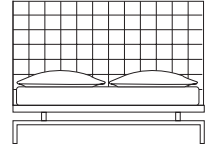

Standard	L/W 175	H 126	P/D 209	per materasso	L/W 170	P/D 197
	W 68,9"	H 49,6"	D 82,3"	for mattress	W 66,9"	D 77,5"
Queen-Size	L/W 161	H 126	P/D 215	per materasso	L/W 150	P/D 203
	W 63,4"	H 49,6"	D 84,6"	for mattress	W 59"	D 79,9"
King-Size	L/W 205	H 126	P/D 215	per materasso	L/W 193	P/D 203
	W 80,7"	H 49,6"	D 84,6"	for mattress	W 76"	D 79,9"
Europe	L/W 190	H 126	P/D 212	per materasso	L/W 180	P/D 200
	W 74,8"	H 49,6"	D 83,5"	for mattress	W 70,9"	D 78,7"

Boss bed LOW art. 9017

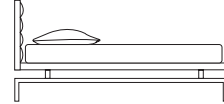
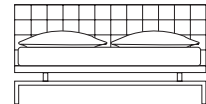

Standard	L/W 175	H 98	P/D 209	per materasso	L/W 170	P/D 197
	W 68,9"	H 38,6"	D 82,3"	for mattress	W 66,9"	D 77,5"
Queen-Size	L/W 161	H 98	P/D 215	per materasso	L/W 150	P/D 203
	W 63,4"	H 38,6"	D 84,6"	for mattress	W 59"	D 79,9"
King-Size	L/W 205	H 98	P/D 215	per materasso	L/W 193	P/D 203
	W 80,7"	H 38,6"	D 84,6"	for mattress	W 76"	D 79,9"
Europe	L/W 190	H 98	P/D 212	per materasso	L/W 180	P/D 200
	W 74,8"	H 38,6"	D 83,5"	for mattress	W 70,9"	D 78,7"

Boss bed WIDE art. 9027

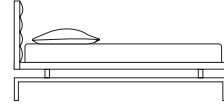
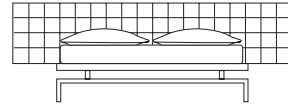

Standard	L/W 263	H 98	P/D 209	per materasso	L/W 170	P/D 197
	W 103,5"	H 38,6"	D 82,3"	for mattress	W 66,9"	D 77,5"
Queen-Size	L/W 263	H 98	P/D 215	per materasso	L/W 150	P/D 203
	W 103,5"	H 38,6"	D 84,6"	for mattress	W 59"	D 79,9"
King-Size	L/W 263	H 98	P/D 215	per materasso	L/W 193	P/D 203
	W 103,5"	H 38,6"	D 84,6"	for mattress	W 76"	D 79,9"
Europe	L/W 263	H 98	P/D 212	per materasso	L/W 180	P/D 200
	W 103,5"	H 38,6"	D 83,5"	for mattress	W 70,9"	D 78,7"

LOOK AT ME



art. 90/B  
L/W 93 H 210  
W 36,6" H 82,7"



art. 90/A  
L/W 79,5 H 210  
W 31,3" H 82,7"



art. 90/D  
L/W 66 H 210  
W 26" H 82,7"

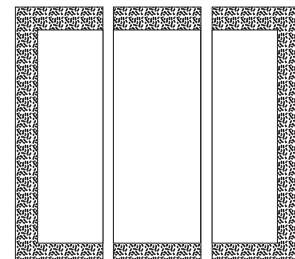

art. 90/C  
L/W 230 H 210  
W 90,5" H 82,7"

QUADRUS

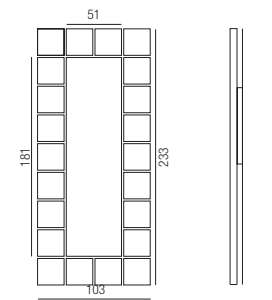

art. 91  
L/W 103 H 233 P/D 2,5  
W 40,5" H 91,7" D 1"

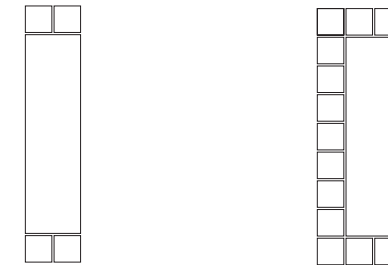

art. 95 L/W 51 H 233 P/D 2,5  
W 20" H 91,7" D 1"

art. 94 L/W 77 H 233 P/D 2,5  
W 30,3" H 91,7" D 1"

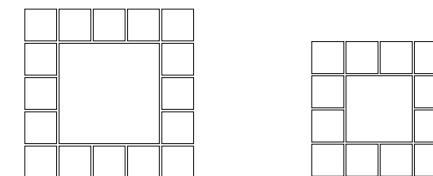

art. 92 L/W 129 H 129 P/D 2,5  
W 50,8" H 50,8" D 1"

art. 93 L/W 103 H 103 P/D 2,5  
W 40,5" H 40,5" D 1"

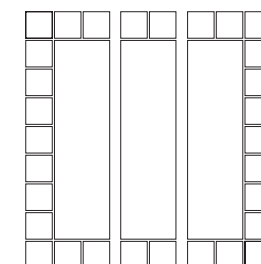

art. 96  
L/W 205 H 233 P/D 2,5  
W 80,7" H 91,7" D 1"

A. B. NORMAL

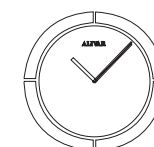

art. 9000  
Ø 140 P/D 6  
Ø 55,1" D 2,4"

IBIS

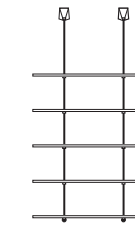

Composizione / Combination 5008  
L/W 120 H 218 P/D 44,5  
W 47,2" H 85,8" D 17,5"

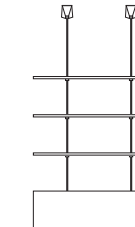

Composizione / Combination 5013  
L/W 120 H 228 P/D 44,5  
W 47,2" H 89,8" D 17,5"

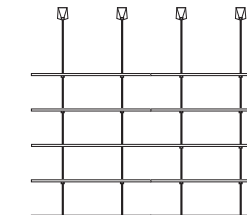

Composizione / Combination 5010  
L/W 240 H 218 P/D 44,5  
W 94,5" H 85,8" D 17,5"

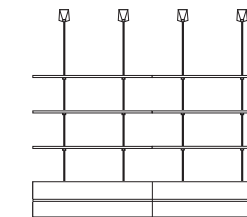

Composizione / Combination 5017  
L/W 240 H 218 P/D 44,5  
W 94,5" H 85,8" D 17,5"

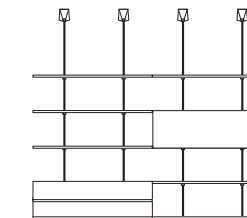

Composizione / Combination 5018  
L/W 240 H 218 P/D 44,5  
W 94,5" H 85,8" D 17,5"

# ALIVAR

## NEL MONDO IN THE WORLD

### NORD AMERICA E AMERICA LATINA

MESSICO  
VENEZUELA  
COLOMBIA  
PERU'  
URUGUAY  
COSTARICA

### STATI UNITI

Citibank Offices  
Sony Lobby  
Ann Taylor Shops  
Bergdorf Goodmann  
Barney's New York  
Daniel Day Lewis  
Don Johnson  
Jennifer Lopez

### EUROPA

ITALIA  
Gianni Versace Milano  
Aeroporto di Bologna  
Navi Costa Crociere  
Aeroporto di Bolzano  
Pitti Firenze  
Cafè Renault Roma  
Fiera Bolzano  
Comune di Roma  
Banca d'Italia  
Credito Bergamasco  
Hotel Rafael Roma  
Officine Panerai  
Hotel Le Meridien Lingotto  
Torino

Banca Antoniana  
A.C. Fiorentina  
Comune di Napoli  
Mada Hotels  
Relax Hotels  
Hotel Michelangelo (Chianciano Terme)  
Biblioteca Nazionale di Firenze  
Uffici della Provincia di Latina,  
La Farnesina, Roma  
Ministero dell'Interno, Roma

OLANDA  
SNC Bank  
Den Bosch Avero Verz. Mij  
Leeuwarden Groene Land Verz.  
Groningen  
De Amersfoortse Verz.  
Amersfoort Psych Centrum  
Zon & Shild  
Bilthoven KPMG Accountancy  
Nieuwegein  
Hotel La Bergère Maastricht

GRECIA  
Ioniki Bank of Greece  
Interamerican Group  
Nestle Headquarters Athens  
Piraeus Bank Athens

REGNO UNITO  
GRAN BRETAGNA  
Axon Solutions London  
ICAS Edinburgh  
The Park Restaurant London  
Goldman Sachs

Revlon  
Leaf Bar Manchester  
The Willow Tea Room Glasgow  
The Kensington Hotel London  
London Mel B (Scary Spice)  
Spice Girls  
Spice Cube Restaurant

### IRLANDA

Air Lingus

### ISLANDA

Radisson sas  
1919 Hotel Reykjavik

### REPUBBLICA CECA

Villa Tugendhat Brno  
Maximilian Hotel Prague

### GERMANIA

Bosch Offices  
ABC Bank Berlin  
Hochtief Niederlassung Bayern

### LUSSEMBURGO

WGZ Bank

### SPAGNA

Hotel Valencia Palace Valencia  
Hotel San Roque Tenerife  
Caya General de Ahorros  
Granada

### BELGIO

Zwart Huis Knokke

### NORVEGIA

### FRANCIA

### AUSTRIA

### SVIZZERA

### PORTOGALLO

### FINLANDIA

### OCEANIA

### AUSTRALIA

### Bally Shop

### Polo Ralph Lauren

### Deutsche Bank

### Citibank Limited

### Reader's Digest

### Sony Music

### University of Technology of Sidney

### Museum of Applied Arts &

### Sciences

### Telecom Australia Ltd

### Prospect Electricity Sidney

### Crown Casino Melbourne

### NEW ZEALAND

### MAURITIUS

### ASIA

### MEDIO ORIENTE

### KUWAIT

### ISRAELE

### CIPRO

### TURCHIA

### EMIRATI ARABI

### ARABIA SAUDITA

### LIBANO

### Credit Commercial

### de France Beirut

### ASIA

### ESTREMO ORIENTE

### MALESIA

### Musictheque Istana

### Hotel Kuala Lumpur

### SINGAPORE

### Rabo Bank

### Government of Singapore

### Guess Boutique

### Siemens

### HONG KONG

### Sithe Asia

### GIAPPONE

### Pachinko Tower Tokyo

### TAIWAN

### COREA

### INDONESIA



A.D. Adriani & Rossi Edizioni  
Foto Studio Indoor  
Fotolito - Zincografia Verona  
Stampa Grafiche Antiga  
Printed in Italy Novembre 2005



Alivar A. Studio s.r.l. si riserva la facoltà di apportare modifiche tecniche ai propri prodotti. Sono possibili differenze di colore dovute dalla tecnica di stampa.  
Alivar A. Studio s.r.l. reserves the right to change its products without notice. Printed catalogue colours may slightly differ. Printed in Italy Aprile 2005